

MO-FLEX GROW-FINISH BUILDING PLAN

Plan No. MO1-726-94C1

Developed by: Joseph M. Zulovich, Ph.D., P.E.
Commercial Agricultural Engineer
Animal Structures Specialist
University Extension - Commercial Agriculture Program
Agricultural Engineering Department
University of Missouri

© 1995 University of Missouri

WARRANTY DISCLAIMER:

The plan contained herein provides drawings and recommendations for the grow-finish building only. The drawings and recommendations are for a building based on 1994 Missouri structural requirements. NEITHER THE UNIVERSITY OF MISSOURI, UNIVERSITY EXTENSION NOR THE COOPERATIVE EXTENSION SERVICE, OR THEIR RESPECTIVE AGENTS OR EMPLOYEES, HAVE MADE, AND DO NOT HEREBY MAKE, ANY REPRESENTATION, WARRANTY OR COVENANT WITH RESPECT TO THE DRAWINGS OR RECOMMENDATIONS HEREIN. Additional professional services will be required to tailor this plan to your situation, including but not limited to:

- assurance of compliance with local codes and regulations;
- development and/or review of specifications for materials and equipment;
- selection of proper site providing adequate natural resource base;
- supervision of site preparation, bid letting and construction;
- development of a manure storage system and nutrient management plan;
- and provisions for utilities, roads and/or other access.

TABLE OF CONTENTS

	<u>Page</u>
WARRANTY DISCLAIMER	ii
Acknowledgments	v
Sizing a MO-Flex Grow-Finish Building	1
Management Considerations	1
Pen Size Impact	2
Manure Removal Impact	2
Multiple Rooms and Load-out Rooms	3
Available Building Sizes	3
Structural Specifications for a MO-Flex Grow-Finish Building	5
Structural Lumber Specifications	5
Ceiling Construction	5
Truss Selection	6
Truss Erection	6
General Concrete Specification	7
Reinforcing Steel Requirements	7
Concrete Finishes	8
Concrete Slat Requirements	8
Insulation Requirements	8
Vapor Retarder Requirement	8
Interior Surfaces	8
Exterior End Walls	9
Interior Partition Walls	9
Post Frame Bracket Installation	9
Insulated Roof Construction	10
Manure Removal System Management	11
Flush Systems	11
Pit Recharge Systems	11
Hairpin Gutter Systems	11
Ventilation Specifications for a MO-Flex Grow-Finish Building	12
Sidewall Curtain Information	13
Ventilation Specifications for Flat Ceiling with Flushing Option	13
Ventilation Specifications for Open Ridge with Flushing Option	15
Ventilation Specifications for Flat Ceiling with Under Alley Plenum Option	16
Ventilation Specifications for Flat Ceiling with Hairpin Gutter Option	17

Specifications for Heat Stress Relief Systems	19
Specifications for Attic Ventilation and Opening Requirements	19
Specifications for Heater Requirements	20
Plumbing and Electrical Information	21
ADDITIONAL RESOURCES	22
APPENDICES	
A. Missouri Siphon Flush Tanks	24
B. Flush Gutter Water Trap	27
C. Anaerobic Lagoon Systems	28
Submerged Inlet into Lagoon	29
Surface Inlet into Lagoon	30
Wet Well Installation for Lagoon Recycle Pump	31
D. Concrete Manure Storages	32
E. Fan Sizes for Flat Ceiling with Flushing Option	33
F. Fan Sizes for Flat Ceiling with Hairpin Gutter Option	36
G. Pit Ventilation Pipe Designs for Hairpin Gutters	39

Acknowledgments

The author, Joe Zulovich, would like to acknowledge the help of other Commercial Agriculture Swine Team members during the development of this plan. John Hoehne, Commercial Agricultural Engineer (Animal Waste Specialist) and Charles Fulhage, Extension Agricultural Engineer, added input to the manure handling portions of the plan as well as reviewing several other portions of the plan during development. Rick Tubbs, Commercial Agriculture Swine Veterinarian, added input to the management and operational parameters of this plan. Rex Ricketts, Director of the Commercial Agriculture Program, provided a significant amount of additional funding which was used to obtain additional engineering drafting help to complete the drawing portions of the plan.

MO-FLEX GROW-FINISH BUILDING PLAN

See MO-Flex Grow-Finish Building Plan MO1 for related information

The MO-Flex Swine Building System was developed to provide Missouri's independent swine producers with a comprehensive, standardized building plan package using current technology. The MO-Flex Grow-Finish Building is one production stage in the MO-Flex Swine Building System. Plan packages have been developed for each of the four stages of swine production; farrowing, nursery, grow-finish, and breeding-gestation. A plan package includes 20 - 17" x 22" sheets of construction drawings and a manual. The drawings show how a building should be built. This accompanying manual provides additional construction and specification details as well as a discussion of the design, operation and maintenance requirements of the building system.

Sizing a MO-Flex Grow-Finish Building

The number of head a grow-finish building holds will depend upon the group size and schedule of an operation. The number of rooms a building will have depends not only on the group size and schedule but also on the available building site and other needs of an operation.

Management Considerations

All-in/All-out management (AIAO) should be planned for with any new grow-finish building. AIAO reduces the risk of disease because a given room or building is emptied and cleaned before any new pigs are brought into the room. Planning building sizes to include AIAO management requires not only the size of group or batch of pigs but also the age difference between pigs in a single air space. A single air space is a building or room within a building that is operated as one continuous space for a group of pigs.

For a "closed" farrow-to-finish operation (an operation that does not bring in any weaner or feeder pigs), the batch or group size is the number of pigs weaned as a group. In the grow-finish stage of a closed operation, batches or groups of pigs coming from the nursery stage could be grouped together if the age difference is not too large. About a two week maximum age difference between the oldest and youngest pig should be allowed within a single grow-finish air space. If a weekly production schedule (weaning every week) is used, no more than two weeks of production should be housed within a single air space. If groups of pigs are produced less frequently than weekly, separate rooms for each group should be considered for grow-finish facilities. For an operation "assembling" feeder pigs to fill grow-finish facilities, the batch or group size is the number of pigs required to fill a given grow-finish air space. The batch of pigs should be close in age and be obtained from a single source. Mixing pigs of different ages and/or from different sources should be avoided. AIAO management is usually easy to implement because new pigs are not brought in until the previous group is removed and the building is cleaned. When considering the size of a grow-finish building for this type of operation, the capacity of the facility should be sized to easily facilitate shipping either to load a facility or to market the pigs. Generally, grow-finish facilities assembling feeder pigs size facilities in increments of 200 pigs per air space (ie. 200, 400, 800 or 1000 head per air

space).

In summary, a grow-finish building should be sized for groups of pigs being produced or assembled on a given schedule. If similar group sizes produced or assembled on a given schedule, grow-finish buildings can easily be properly sized and managed to include AIAO management.

Pen Size Impact

The MO-Flex Grow-Finish Building Plan uses 10' by 19' pens down each side of a nominal 40-foot wide, totally slatted building. The 10' by 19' pens are sized to hold 20 to 25 pigs and provide 9.5 to 7.6 ft² gross pen area per pig. A particular building can have any number of individual rooms as required by a corresponding production system. The building length can be varied depending upon total pig capacity, but the final building length needs to be evenly divisible by four to optimize material usage.

Manure Removal Impact

Manure should be removed from any swine building on a regular basis. When manure is removed from the building on a frequent basis, the ventilation system can be simplified because pit ventilation (air removal from manure/waste storage area) is not needed to help maintain indoor air quality.

Flushing under slats is the preferred manure removal system. No pit ventilation is required if flushing frequency for each gutter in a building is two hours or less. The flush system selected will have an impact on building length. Flush systems using flush tanks located inside the building require additional building length. A number of pen capacity combinations are not evenly divisible by four, so the additional space needed for flush tanks is usually not much of an issue. A siphon flush tank design (MO Siphon Tank) developed by Agricultural Engineering at the University of Missouri is included with this plan. This MO Siphon Tank is constructed as an integral part of the building, so it minimizes additional building length. Other available flush tanks having the same capacity as the MO Siphon Tank typically require more building space. This building plan allows for a minimum of 8' additional building length for other available flush tanks. One needs to determine the space requirement of the selected flush tank to insure that enough space is allowed for the tank during this initial building sizing phase. Another flush system design uses overhead pipe storage and therefore does not require additional building length for the system. This overhead storage flush system allows for the absolute minimum building length for the number of pigs housed.

Other manure removal systems available with this plan include pit recharge and gravity drain gutters ("Pull-plug" systems). The pit recharge system is a shallow pit that is filled with a minimum of 12" of recycled water from an anaerobic lagoon after the pit is drained on a regular basis. The gravity drain gutter system is a reversing hairpin gutter that drains the liquid manure either to an outside manure storage or an anaerobic lagoon. These two manure removal options should have mechanical pit ventilation systems. However, these two manure removal options generally do not impact on the length of the building.

Another consideration for manure removal impact includes the possible manure storage options available at the site a building will be constructed. Flush systems and pit recharge systems assume an anaerobic lagoon is available for manure storage. The gravity drain gutter system can be used in

conjunction with an anaerobic lagoon or a liquid manure system. If an anaerobic lagoon cannot be built near the building site, the gravity drain gutter system is the manure option for the building.

Multiple Rooms and Load-out Rooms

Multiple grow-finish rooms can easily be incorporated into a MO-Flex Grow-Finish Building. The group or batch size of pigs for a given operation will determine the size of a room to incorporate AIAO management. The number of rooms per building can be determined by using Table 1 which shows total pig capacity for various lengths of buildings. If multiple grow-finish rooms are used, a ventilation system is designed for each room. The feed delivery system needs may be different for multiple rooms over what is required for a single room building.

Load-out rooms should be considered if more than three grow-finish rooms are to be placed in a single building. A load-out room is located between two grow-finish rooms such that the pigs from either grow-finish room can be loaded in or out of the given grow-finish room without having to move the pigs through another room of pigs. If a building is to have only two rooms, the two rooms could be loaded and unloaded from either end of the building, or a load-out room can be located in the center of the building such that either grow-finish room is loaded or unloaded through the common load-out room.

Interior walls between different rooms within a MO-Flex Grow-Finish Building are assumed to not add to the total length of a building. Interior walls can be 2x4 stud frame walls. Pens located along an interior wall can use the wall as a pen partition. If pigs are exposed to an interior partition wall, the interior wall surface must be pig resistant.

Available Building Sizes

Table 1 gives the total pig capacity range for buildings of various lengths. The total pig capacity can be divided into any number of rooms depending upon a particular needs of a swine operation. The building lengths are divisible by four to maximize material use. The building lengths given in Table 1 account for additional length required for various manure removal options. Walls which divide a building into separate rooms are assumed to not increase the building length. No alleys which would run the width of the building are included in the lengths from Table 1. If alleys running the width of the building are desired, add the total alley widths to the length of the building. Remember that the total building length should be divisible by four.

Table 1. MO-Flex Grow-Finish Building Lengths

Total No. Pens	Total No. Pigs	Building Length in Feet Using		
		MO Siphon Tank	Other Tanks	Other ¹
8 ²	160-200	44	48	40
10 ²	200-250	56	60	52
12	240-300	64	68	60
14	280-350	76	80	72
16	320-400	84	88	80
18	360-450	96	100	92
20	400-500	104	108	100
22	440-550	116	120	112
24	480-600	124	128	120
26	520-650	136	140	132
28	560-700	148	148	140
30	600-750	160	160	152
32	640-800	168	168	160
34	680-850	180	180	172
36	720-900	188	188	180
38	760-950	200	200	192
40 ³	800-1000	208	208	200
42	840-1050	220	220	212
44	880-1100	228	228	220
46	920-1150	240	240	232
48	960-1200	248	248	240

¹ Other includes overhead storage flush systems, pit recharge systems and gravity drain gutter systems. Other also indicates proposed individual room sizes for buildings with multiple rooms.

² The 8 and 10 pen sizes would probably not be individual building sizes but could be individual room sizes in a multiple room building.

³ Total building length is limited to 200' for under alley ventilation plenum option using pit recharge manure handling. Building cross section option shown on Sheet P2 is limited to a maximum of a 200' long building.

Note: If alleys running the width of the building and/or load-out rooms are desired, the building length is increased above values shown in Table 1 for a given number of pens by the sum of the alley width(s) and/or room width(s).

Structural Considerations for a MO-Flex Grow-Finish Building

Design loads used for the building structure follow Standard ANSI/ASCE 7-93, Minimum Design Loads for Buildings and Other Structures. The live load for the roof structure was 20 psf (pounds per square foot). Wind loads for the structure were based on an 80 mph wind speed. Appropriate dead loads were included. Structural design details given in this plan meet required load conditions for Missouri. NOTE: If changes are made to structural design of the building, the changes shall be certified by an engineer to insure the proposed changes will provide adequate strength to meet required loads at the location the building is constructed.

The structural design details included in this plan should not be used in areas where either the design roof live load (ie. snow load) or the design wind speed is exceeded. Areas where either the roof live load or the wind speed are exceeded require different structural design details than ones included in this plan. An engineer will be required to redesign and certify the necessary structural changes so that the new design will meet the load conditions of the new area.

Structural Lumber Specifications

Lumber quality of all structural components is to be Number 2 Southern Pine or better. Treated lumber is to be 0.6 PCF CCA treated. Structural components include 2x6 post members, bottom plate, 2x8 bottom girt, 2x10 top girt, and purlins, either 2x4 or 2x6. Structural members for this MO-Flex Grow-Finish Building exposed to moisture include 2x6 post members, bottom plate, 2x8 bottom girt, and 2x10 top girt and need to be CCA treated members. If a lesser quality of lumber is used, the structural design detail may be inadequate and may require an engineer to redesign the structure for poorer quality lumber.

Ceiling Construction

Construction of the insulated ceiling may be accomplished by several different techniques. Owners and builders should determine with what and how a ceiling is actually constructed. The finished ceiling construction should have an R-value of 30 and have the proper interior surface characteristics. Two acceptable methods are given below.

One method of ceiling construction is to attach 29 ga. corrugated aluminum directly to the bottom chord of the trusses after a vapor barrier is installed. If a metal ceiling construction is used, the truss manufacturer should be notified when purchasing trusses because the ceiling may provide the necessary bottom chord bracing.

Another method of constructing the ceiling is to use a flexible plastic sheet material for the ceiling. The flexible plastic sheet can provide the desired surface characteristics and hold insulation adequately but will not provide bottom chord bracing. Additional framing may be required to provide the necessary bottom chord bracing.

If no ceiling is constructed, bottom chord bracing will probably be required.

Truss Selection

Trusses for the MO-Flex Swine Buildings have the following specifications:

Roof Slope:	4/12
Loading Criteria:	For insulated ceiling (20#-4#-0#-5#) Top chord live load - 20 psf Top chord dead load - 4 psf Bottom chord live load - 0 psf Bottom chord dead load - 5 psf For insulated roof line and no ceiling (20#-7#-0#-1#) Top chord live load - 20 psf Top chord dead load - 7 psf Bottom chord live load - 0 psf Bottom chord dead load - 1 psf
Support Width:	41' (Exterior posts are 41'-6" apart [exterior face to exterior face])
Top Chord Overhang:	18" to help protect curtain sidewalls
Truss Spacing:	4' o.c.
Purlins:	For insulated ceiling, 2x4's at 24" o.c. attached flat on top For insulated roof, 2x6's at 39" o.c. attached on edge
Bottom Chord Bracing	Follow BWT-76 from Truss Plate Institute. Indicate construction method of ceiling (if used).

Trusses should be purchased from a truss supplier. Truss design should be certified by an engineer to meet the required loading.

Truss Erection

Truss erection and temporary bracing are important considerations during the design process of a truss. However, this component is the most difficult to manage from the building designer's point of view because of differences between construction crews and locations. Even though erection is the most difficult to manage, truss engineering firms are greatly concerned because of the potential loss of human life and property losses due to a construction accident during truss erection. Information on proper truss erection is available from "Bracing Wood Trusses" (BWT-76) and Handling and Erecting Wood Trusses (HET-80). Both pieces are available from the Truss Plate Institute. "Commentary and Recommendations for Handling, Installing and Bracing Metal Plate Connected Wood Trusses" (HIB-91) is another document from the Truss Plate Institute and provides diagrams and specifications for getting trusses safely installed.

General Concrete Specification

Concrete is used in the MO-Flex Grow-Finish Buildings for footings, exterior stub walls, flooring for manure handling systems, interior stub walls and/or concrete siphon flush tanks. Concrete specifications are as follows:

- Minimum 3,500 psi compressive strength (about a 6 bag mix),
- Air-entrained,
- Maximum aggregate size of 1 inch,
- Maximum slump of 4 inches.

This level of concrete quality is required to obtain the desired finishing and durability characteristics.

Reinforcing Steel Requirements

Reinforcing steel should be included in all structural concrete for MO-Flex Grow-Finish Swine Buildings. Structural concrete includes slab on grade construction, footings, exterior structural walls and/or concrete siphon flush tanks. Reinforcing steel is required not only for structural strength but also for temperature and shrinkage reinforcement.

Footings: Footings require two #4 bars running the entire length and located about 8" apart in the lower third of the footing. When footings go around corners, each corner should have #4 dowels to maintain the steel around each corner.

Slabs on Grade: Concrete floors 4" thick require #4 bars at 18" o.c. in both directions and located at the vertical center of the slab.

Exterior Structural Walls: Steel requirements for 8" exterior concrete walls include both vertical and horizontal steel reinforcing. Vertical steel should be #4 bars, 16" on center throughout the length of the exterior walls. Horizontal steel should be #4 bars, 10" on center (maximum) throughout the height of the exterior walls. For 4' high exterior walls, five (5) rows of #4 bars should be used (See sheet F4). For 5' high exterior walls, seven (7) rows of #4 bars should be used (See sheets P3 and/or H3).

Concrete Siphon Flush Tanks: If MO Siphon Flush Tanks are to be built, reinforcing steel requirements are detailed in drawings on sheets F7 and F9. Steel requirements for the siphon flush tank provide structural strength. If the steel requirements are not followed, a tank failure is possible.

Above steel reinforcing requirements are given as general recommendations. Drawings that accompany this plan should be examined to find locational details for reinforcing steel requirements of any particular concrete structural components.

Concrete Finishes

Structural Walls and Siphon Tank: All vertical structural walls, including concrete siphon tank components, should be vibrated during placement of the concrete. Vibrating is required to minimize honeycombing; insure that concrete entirely fills forms and also adheres to all connection and steel reinforcing.

Slabs on Grade: Concrete slabs on grade should be finished to a smooth float finish. The finish should be smooth enough so that manure removal is not inhibited. Also, the finish should be such that no aggregate or holes are left at the top surface to allow manure to easily begin corrosion of the concrete surface.

Alleys or Walkways: Alleys or walkways where human or animal traffic exist should have a non-skid surface. Concrete surfaces for alleys or walkways should first have a smooth float finish and then be completed with light to medium broom finish. The float finish is first required to give a durable surface, and the broom finish is to provide a non-skid surface for traffic.

Concrete Slat Requirements

Concrete slats for the MO-Flex Grow-Finish Building are standard, commercially available grow-finish gang slats. Slot width should be 1 inch. Actual slat width and surface characteristics are left for the building owner to select. Flush and hairpin gutter manure handling options use only 10' gang slats. Pit recharge option with under alley plenum uses 8' and 10' gang slats.

Insulation Requirements

Insulation levels are shown on the drawings. Insulated components include: building perimeter, exposed concrete walls, frame end walls, and ceiling or roof. Reduced insulation levels from those shown on the drawings will increase heat loss from the building shell and result in higher heating costs.

Vapor Retarder Requirement

A vapor retarder should be placed behind the inside surface material of all insulated building components. An acceptable vapor retarder is 6-mil plastic. The plastic should be continuous and should be either sealed or overlapped at least 6" at joints. Other materials which meet vapor retarder performance of 6 mil plastic may be substituted.

Interior Surfaces

Interior surfaces can be constructed from a variety of materials. Interior surfaces should be non-porous. Surfaces need to withstand repeated high pressure washings using detergents and disinfectants. Typical surfaces include corrugated galvanized metal, corrugated aluminum and glassboard.

Exterior End Walls

Exterior end walls should be constructed as 2x6 stud frame walls using standard framing techniques. The sill plate should be CCA treated and attached to the concrete wall with ½" x 8" anchor bolts at a maximum of 36" on center. Insulation should be placed between the 2x6 studs to provide an R-value of about 19. A vapor retarder should be placed on the inside of the wall just under the interior wall surface. Exterior siding is placed on the outside of the walls.

Interior Partition Walls

Interior partition walls separate any rooms within a building. Several possible methods of constructing interior partition walls exist. One method to construct interior partition walls is presented below as 2x4 stud frame construction. However, any construction practice or methodology that will give the same performance characteristics as the example stud frame construction is acceptable.

A standard 2x4 stud frame construction could be used for all interior partition walls. Bottom sill plate should be CCA treated and lag bolted to the floor. Top sill plate should be framed between bottom chords of adjacent trusses. The framing between trusses for the top plate of partition walls should not interfere with the proper function of the trusses. The 2x4 studs could be placed on either 16" or 24" centers. The selection of surface material will dictate stud spacing. Interior surfaces should be placed on both sides of the 2x4 studs. If pigs will have access to an interior partition wall, the pig contact area should be covered by a smooth, durable, joint free, pig resistant surface. A wall surface is more pig resistant if all joints at pig level are eliminated. Interior partition walls do not need to be insulated.

Post Frame Bracket Installation

The post frame bracket attaches the three 2x6's forming the post to the exterior concrete stem wall. The bracket connection provides a rigid joint at the bottom of the post. No knee braces are required for the design loads because the steel bracket connection provides the necessary lateral wind resistance. The bracket must be installed as shown on the drawings. To aid in construction, a template can be constructed and used to help with placing the four anchor bolts (4 - ½" x 8" anchor bolts) required for each post bracket. The four anchor bolts for each bracket must be properly placed in the exterior concrete stem walls when the concrete walls are constructed. When done properly, the bracket connection will provide a rigid connection between the concrete stem wall and the post frame structure.

The use of the post frame bracket removes the need for knee braces between the trusses and the posts or for interior shear walls. If the post frame bracket is not installed, knee braces or shear walls must be designed into the building to provide lateral wind stability.

Insulated Roof Construction

Insulated roof construction is designed in conjunction with the open ridge ventilation system option shown on Sheet F3. No ceiling is built when using insulated roof construction so bottom chord bracing will probably be required.

The recommended finished construction of the insulated roof includes ½" fire-rated exterior grade plywood serving as the interior surface, vapor retarder of 6 mil plastic, R-19 insulation, 2x6 purlins on 39" centers and metal roofing. Installing the plywood after the 2x6 purlins have been installed usually requires significant labor input to fit the plywood between the trusses. An alternative construction technique is to assemble the plywood, vapor retarder plastic and 2x6 purlins as units on the ground prior to erecting the trusses. When the trusses are erected, the plywood/vapor retarder/purlin units would be placed on top of the trusses and fastened. The 2x6 purlins are attached to the trusses using nailing cleats, and the plywood is also nailed to the truss. By constructing pre-fab units, the total construction labor requirement should be reduced because the plywood lies on top of the trusses and does not have to be cut and fitted between the trusses.

The insulated roof construction is a recommended method to build a facility which has an open ridge ventilation system. Other methods could be adapted to the design shown on Sheet F3 to provide an open ridge ventilation system. Another method is sometimes called a "chimney" building. The ridge remains open as shown. The insulation and interior surface could follow two interior truss web members forming an inverted "V" in the truss. A flat ceiling would be installed covering the remainder of the truss width. Batt insulation is typically used for the inverted "V" sections and blown-in insulation is typically used above the flat ceiling portion. A vapor retarder is required on the outside surface of the interior surface material. Detailing to seal the top of the ridge (point of the "V") must be carefully done so no moisture can enter the insulated attic area of this construction.

Manure Removal System Management

The management of the manure removal system will depend upon the system selected. All available systems remove the manure from the animal space and building to either an anaerobic lagoon system or an outside manure storage facility. Additional information about anaerobic lagoon systems is provided in Appendix C. Additional information about outside manure storages is provided in Appendix D.

Flush Systems

Flush systems require an anaerobic lagoon system. Recycled water from an anaerobic lagoon is used to wash collected manure out from under the slats. A gutter is located under each row of slat and runs the length of the building. Each gutter should be flushed about every 2 hours to help provide for good indoor air quality. However, each gutter should be flushed at least 5 times per day to hydraulically remove the collected manure. If manure build-up under the slats is observed, more frequent flushing of the gutter is required.

MO Siphon Tank: MO Siphon Tank operational and start-up procedures are given in Appendix A. Construction details for a MO Siphon Tank are given in the drawings.

Other Flush Devices: Other flush release devices can be used. Installation and operating information should be obtained from the supplier or manufacturer.

Pit Recharge Systems

Pit recharge systems require an anaerobic lagoon system. When empty, the shallow pits of a pit recharge system are filled with a minimum of 12" of recycled water. Pits should be recharged at a minimum rate of 1" per hour. The recycle pump capacity, in gpm (gallons per minute), can be determined by multiplying the pit floor area in square feet times 0.623. A recharge pit should be drained and recharged every 5 to 10 days. If the air quality within a building is considered poor, increasing the frequency of draining and recharging the shallow pit will help improve indoor air quality.

Hairpin Gutter Systems

Hairpin gutter systems can be used with either an outside manure storage or an anaerobic lagoon system. The hairpin gutter has two locations where the gutter can be drained. One location should be used to drain the gutter, and then the other location should be used the next time the gutter is drained. This alternating drain procedure helps minimize solids build-up in the gutter. A hairpin gutter can be drained when a minimum of 12" of material is stored in the gutter (about weekly). After a gutter is drained, a minimum of 1" of fresh water should be added to minimize manure from drying and sticking to the gutter floor. The added fresh water helps reduce ammonia level within the building. Ideally, the gutter should have 12" of liquid when elevated ammonia levels are noticed within the building. If elevated ammonia levels are noticed before 12" of liquid is present, add more fresh water when the gutter is initially drained. The additional fresh water will increase ammonia holding capacity of the stored liquid and force the gutter to fill more quickly.

Ventilation Specifications for a MO-Flex Grow-Finish Building

The ventilation performance specifications provide ventilation information for each different building option. The four building options are flat ceiling with flush; open ridge with flush; flat ceiling with under alley plenum; flat ceiling with hairpin gutter. Within each building option, a range for animal capacity exists, and ventilation performance specifications are given for all probable room sizes. Ventilation rates are given for minimum requirements for both small and large pigs as well as for mild weather mechanical ventilation. Mild weather is addressed because the sidewall curtains should not operate unless the outside temperature is above freezing. If a sidewall curtain operates when the outside air temperature is below freezing, the curtain might be frozen shut, or worse yet, the curtain could freeze open. Hot weather ventilation rates are not provided. All options are curtain sided buildings and use natural (non-mechanical) ventilation for summer conditions.

Performance Versus Prescriptive Specifications: The ventilation specifications in this section are performance specifications and not prescriptive specifications. Prescriptive specifications provide the necessary specific details and procedures to purchase and install a given piece of equipment. Performance specifications describe the desired characteristics required for the necessary equipment but do not provide specific prescriptive details which tell exactly which product or brand to use. A performance specification example for a ventilation fan is "The fan should provide 3500 cfm (cubic feet per minute) at 0.10" w.c. (inches of water column) and is typically an 18" diameter fan." But the performance specification does not tell exactly what fan brand or model to purchase.

General Ventilation Performance Specifications: A few general ventilation performance specifications apply for all building options. First, an absolute minimum ventilation rate of 3 cfm per pig is recommended for all options. Second, the minimum ventilation rate should be increased to 7 cfm per pig as the pigs reach market weights. A variable minimum ventilation rate is required because the pigs will grow considerably in the facility. As pigs grow, the larger minimum ventilation rate is required. Third, warm and hot weather ventilation is provided primarily by opening the sidewall curtains. Fourth, heat stress relief systems are required for all building options. The heat stress relief systems complement the existing ventilation system and are comprised of sprinklers and possibly stirring fans.

Indoor Thermal Environment Requirements: Providing an environment for good grow-finish pig performance is a main goal of facility. The inside air temperature should be maintained between 65 and 70 °F. The inside relative humidity should be maintained between 40 and 60%. Air movement at pig level during winter may be a problem especially for small pigs but is required for thermal comfort during hot weather. During hot weather, heat stress relief systems should begin operating when the inside air temperature reaches 82 °F.

Sidewall Curtain Information

All options of the MO-Flex Grow-Finish Building use sidewall curtains. Curtain material for all options is assumed to be uninsulated woven plastic curtain for both north and south sides of buildings. However, if the building owner desires, insulated curtains or other sidewall covers can be used. The curtain material selected must cover the 6' clear opening shown on each side of the grow-finish building. The equipment option selected must also withstand the wind loads created by an 80 mile per hour wind. If wind loads are not considered, a high wind could "peel" the sidewall covering off a building. The exact hardware requirements and installation instructions should be obtained from the supplier or manufacturer of the curtain systems. The curtain opening and closing device such as a winch should be capable of being integrated with other ventilation control devices.

Ventilation Specifications for Flat Ceiling with Flushing Option

The flat ceiling with flushing option is shown on Sheet F2. As can be seen from the drawing, components of the ventilation system include ceiling inlets, exhaust fan(s) and sidewall curtains. A flat ceiling flush building must be mechanically ventilated because a flush building is constructed on a 1.5% to 2% slope. A building built on a slope will result in one end of the animal space (room) being at a high elevation than the other end. If only curtains were used for minimum ventilation, the lower end of the room would be colder than the upper end. A mechanical ventilation system comprised of exhaust fan(s) and ceiling inlets is not affected by the building slope and can provide a uniform temperature distribution from one end of a room to the other.

Exhaust Fan Specifications: Fan staging is required to allow the minimum ventilation rate to be increased from 3 cfm for small pigs to 7 cfm for large pigs. Usually one fan cannot provide the increased minimum ventilation rate as well as an additional ventilation level. Exhaust fans provide additional ventilation capacity above minimum rates so that the sidewall curtains should not have to operate when outside temperatures are below freezing. The fan performance specifications are provided in Appendix E. The specifications provide recommended fan staging and possible fan sizes for room sizes ranging from 8 pens per room to 48 pens per room in increments of 2.

Inlet Specifications: Inlets need to meet the following criteria. Inlets allow air to enter the animal space from the attic and flow along ceiling toward curtains and center of building. Inlets need to be able to automatically adjust to changes in ventilation rate. Inlets need to be able to be adjusted to different operating static pressures (i.e. static pressure difference between attic and animal space). Inlet must be able to handle sub-freezing attic air temperatures without its performance being affected. Inlet opening length should be about 12' per 10' of room length. For example, a 120' room should have 144' of inlet opening length evenly distributed throughout the length of the room. The inlets should be located at about the third points of the building width. Inlet distribution as described is critical to provide fresh air evenly throughout the animal space. The inlets shown in the drawings could be commercially available ceiling inlets. The actual brand or model of inlet is not critical as long as it meets above criteria. Inlets could be constructed by the user if they meet the above criteria.

Control Recommendations: An integrated controller should be used to control the entire ventilation system. An integrated controller can provide the necessary control for the exhaust fans as well as for sidewall curtain operation via the curtain controller/winch. An integrated controller

can combine the operation of the exhaust fans with the curtains such that the fans operate when the curtain is closed and the fans are off when the curtain is open. An integrated controller can also incorporate the operation of a heater(s) so that only the required minimum ventilation rate is provided when the heater is operating. Operating at only the required minimum ventilation rates during the heating season reduces heating costs. Even though an integrated controller is recommended, controls (thermostats) for individual ventilation components can be used, but setting the controls becomes much more complicated as well as the probability of increased errors.

Operation/Management Information: The variable speed fans in stage one allow for the minimum ventilation rate to be increased as pig grow. The rate should be set at 3 cfm per pig when pigs enter a room (assuming incoming weight of about 50 lbs). The minimum rate should be increased to 5 cfm per pig at 100 to 110 lbs. At about 150 to 175 lbs, the minimum rate should be increased to 7 cfm per pig. These increases can be accomplished by increasing the minimum speed setting for the variable speed fans. The fans should be cleaned and serviced monthly. Inlets should be checked seasonally. Curtains should be repaired as necessary. Additional ventilation maintenance and operational information is provided in Mechanical Ventilating Systems for Livestock Housing Handbook (Midwest Plan Service, 1990) and "Mismatched Fans Throw Ventilation Out of Whack" by A. J. Heber.

Ventilation Specifications for Open Ridge with Flushing Option

The open ridge with flushing option is shown on Sheet F3. As can be seen from the drawing, no fans are used with this option for ventilation. The continuous open ridge provides a continuous outlet for air to leave the building, and the continuous eave openings provide continuous inlets for air to enter the building. The building is built on a 1.5% to 2% slope, but the continuous open ridge configuration compensates for the fact that one end of a room is higher than the other. The open ridge is at a higher elevation than the elevation of the eave inlets throughout the length of the room. So, in winter, cold air will enter through the eave openings at a lower elevation and warm air will exit through the open ridge at the higher elevation. This pattern of air movement will occur throughout the length of the room and minimize temperature variation from one end of the room to the other.

Adjustable Open Ridge System Performance Specification: The open ridge should have at least an 8" clear opening. The ridge opening should be automatically adjustable. Several manufacturers exist capable of supplying an automatic, adjustable opening ridge system. The supplier of the ridge system must supply the construction details for the ridge system. A manually adjusted ridge opening system could be built, but the temperature control within the facility will be compromised. Additional information on open ridge ventilation systems can be found in Natural Ventilating Systems for Livestock Housing (Midwest Plan Service, 1989).

Eave Opening Information: A 4" eave opening into the facility animal spaces must exist between all trusses on both sides of the building. The eave openings provide for the inlet and distribution of incoming ventilation air during cold weather. The opening can have 3" vent doors which partially close the eave opening during extremely cold and stormy weather. The eave openings should never be completely closed. Additional discussion of eave openings and a diagram showing the optional vent door can be found in Natural Ventilating Systems for Livestock Housing (Midwest Plan Service, 1989).

Open Ridge Ventilation Control System: The control system for an adjustable open ridge system should be capable of automatically controlling the ridge system and the curtain openers. Usually the control system for the open ridge system can incorporate the curtain opener system. The ventilation rate is controlled by the adjustable ridge system because the control for natural ventilation is at the outlet. Other controls would include thermostats for any heaters and for heat stress reduction equipment (sprinklers and circulation fans). However, some integrated controls may be able to also incorporate heaters and sprinkler/fan systems.

Management Information: The management of an automatic open ridge natural ventilation system is simple after the system is properly installed. Basically the system can operate itself once it is operating correctly. The adjustable ridge system is the component which will allow for even temperature control within the facility. Check with manufacturer for maintenance information.

Ventilation Specifications for Flat Ceiling with Under Alley Plenum Option

The flat ceiling with pit recharge option is shown on Sheet P2. As can be seen from the drawing, components of the ventilation system include ceiling inlets, center alley plenum exhaust system and sidewall curtains. The center alley plenum provides the minimum ventilation rates as well as an additional ventilation level to reduce the possibility of the curtains operating during sub-freezing weather. The overall building length is limited to 200' long because the center alley plenum cannot exceed 200' in length. The sidewall curtains are opened during warm weather to provide the necessary ventilation.

Plenum Fan Specifications: Plenum fan selection is based on the length of plenum a fan is to ventilate. One plenum fan can ventilate up to 100' of plenum length. If more than one fan is required, plenum fans are placed at both ends of the plenum and should be the same size. Plenum fans are all variable speed, and sizes are selected from Table 2. The exact maximum cfm rate will vary depending upon actual fan selected.

Table 2. Plenum Fan Sizes for Different Plenum Lengths

<u>Plenum Length</u>	<u>Fan Size</u>	<u>Minimum Rate (cfm)</u>	<u>Maximum Rate (cfm)</u>
40'	16"	600	2400
50'	18"	750	3500
60'	18"	900	3500
70'	20"	1050	4000
80'	24"	1200	5500
90'	24"	1350	5500
100'	24"	1500	5500

Inlet Specifications: Inlets need to meet the following criteria. Inlets allow air to enter the animal space from the attic and flow along ceiling toward curtains and center of building. Inlets need to be able to automatically adjust to changes in ventilation rate. Inlets need to be able to be adjusted to different operating static pressures (i.e. static pressure difference between attic and animal space). Inlet must be able to handle sub-freezing attic air temperatures without its performance being affected. Inlet opening length should be about 12' per 10' of room length. For example, a 120' room should have 144' of inlet opening length evenly distributed throughout the length of the room. The inlets should be located at about the third points of the building width. Inlet distribution as described is critical to provide fresh air evenly throughout the animal space. The inlets shown in the drawings could be commercially available ceiling inlets. The actual brand or model of inlet is not critical as long as it meets above criteria. Inlets could be constructed by the user if they meet the above criteria.

Control Recommendations: An integrated controller should be used to control the entire ventilation system. An integrated controller can provide the necessary control for the plenum fans as well as for sidewall curtain operation via the curtain controller/winch. An integrated controller can combine the operation of the plenum fans with the curtains such that the fans operate when the curtain is closed and the fans are off or on when the curtain is open. An integrated controller can

also incorporate the operation of a heater(s) so that only the required minimum ventilation rate is provided when the heater is operating. Operating at only the required minimum ventilation rates during the heating season reduces heating costs. Even though an integrated controller is recommended, controls (thermostats) for individual ventilation components can be used, but setting the controls becomes much more complicated as well as the probability of increased errors.

Management Information: The variable speed plenum fans provide the minimum ventilation rate for pigs of all sizes. The rate should be set at 3 cfm per pig when pigs enter a room (assuming incoming weight of about 50 lbs). The minimum rate should be increased to 5 cfm per pig at 100 to 110 lbs. At about 150 to 175 lbs, the minimum rate should be increased to 7 cfm per pig. The minimum 3 cfm rate is given in Table 2 as the minimum rate for the fans. The increases in minimum ventilation rates can be accomplished by increasing the minimum speed setting for the variable speed fans. The fans should be cleaned and serviced monthly. The inlets should be checked seasonally. Curtains should be repaired as necessary.

Ventilation Specifications for Flat Ceiling with Hairpin Gutter Option

The flat ceiling with hairpin gutter option is shown on Sheet H2. As can be seen from the drawing, components of the ventilation system include ceiling inlets, exhaust fan(s), pit ventilation system, and sidewall curtains. The pit ventilation system, sidewall exhaust fan(s) and inlets provide the minimum ventilation rates as well as an additional level to reduce the possibility of the curtains operating during sub-freezing weather. The sidewall curtains are opened during warm and hot weather to provide the necessary ventilation.

Exhaust Fan Specifications: Fan staging is required to increase the minimum ventilation rate to 7 cfm for large pigs. One or more fans are required to increase the minimum ventilation rate as well as provide an additional ventilation level. Exhaust fans provide the additional ventilation capacity above minimum rates so that the sidewall curtains should not have to operate when outside temperatures are below freezing. The fan performance specifications are provided in Appendix F. The specifications provide recommended fan staging and possible fan sizes for rooms sizes ranging from 8 pens per room to 48 pens per room in increments of 2.

Pit Ventilation System: The pit ventilation system is required to ventilate the hairpin gutter system and helps improve indoor air quality. The pit ventilation system operates at the minimum ventilation rate of 3 cfm for small pigs (50 lbs). Designs for the PVC pipe component of the pit system are provided in Appendix G. The designs are for pipes ranging from 30' to 100' long. Fan specifications to operate the pipe system are provided. A fan is recommended to be placed on the end of each pipe and should probably be located on the end of the building. If multiple rooms are used in a building, the pit system can be continuous from one room to the next because all rooms should be ventilated at the 3 cfm rate regardless of pig size in room. By placing fans at each end of a pit ventilation pipe, the fan can be removed, and the pipe cleaned periodically using similar methods as used to clean a chimney. Drain holes to allow any moisture to drain from the pipe are required.

Inlet Specifications: Inlets need to meet the following criteria. Inlets allow air to enter the animal space from the attic and flow along ceiling toward curtains and center of building. Inlets need to be able to automatically adjust to changes in ventilation rate. Inlets need to be able to be adjusted to

different operating static pressures (i.e. static pressure difference between attic and animal space). Inlet must be able to handle sub-freezing attic air temperatures without its performance being affected. Inlet opening length should be about 12' per 10' of room length. For example, a 120' room should have 144' of inlet opening length evenly distributed throughout the length of the room. The inlets should be located at about the third points of the building width. Inlet distribution as described is critical to provide fresh air evenly throughout the animal space. The inlets shown in the drawings could be commercially available ceiling inlets. The actual brand or model of inlet is not critical as long as it meets above criteria. Inlets could be constructed by the user if they meet the above criteria.

Control Recommendations: An integrated controller should be used to control the entire ventilation system except for the pit system in some cases. If the pit system is continuous for more than one room, a separate thermostat in each room should be provided to shut off the pit system if any room ventilated by the system get too cold. An integrated controller can provide the necessary control for the sidewall exhaust fans as well as for sidewall curtain operation via the curtain controller/winch. An integrated controller can combine the operation of the exhaust fans with the curtains such that the fans operate when the curtain is closed and the fans are off when the curtain is open. An integrated controller can also incorporate the operation of a heater(s) so that only the required minimum ventilation rate is provided when the heater is operating. Operating at only the required minimum ventilation rates during the heating season reduces heating costs. Even though an integrated controller is recommended, controls (thermostats) for individual ventilation components can be used, but setting the controls becomes much more complicated as well as the probability of increased errors.

Operation/Management Information: The variable speed fans in stage two allow for the minimum ventilation rate to be increased as pig grow. The minimum rate of 3 cfm per pig is provided by the pit system when pigs enter a room (assuming incoming weight of about 50 lbs). The minimum rate should be increased to 5 cfm per pig at 100 to 110 lbs. At about 150 to 175 lbs, the minimum rate should be increased to 7 cfm per pig. These increases can be accomplished by increasing the minimum speed setting for the variable speed fans. The fans should be cleaned and serviced monthly. Inlets should be checked seasonally. Curtains should be repaired as necessary. Additional ventilation maintenance and operational information is provided in [Mechanical Ventilating Systems for Livestock Housing Handbook](#) (Midwest Plan Service, 1990) and "Mismatched Fans Throw Ventilation Out of Whack" by A. J. Heber.

Specifications for Heat Stress Relief Systems

Heat stress relief systems for grow-finish buildings are composed of sprinkler systems and circulation fans. Sprinklers and circulation fans can be controlled by a separate controller or combined with an integrated controller. Heat stress systems should begin operating when the inside temperature reaches 82 °F.

Sprinkler systems are commercially available and spray water on the pig to create evaporative cooling from the pig skin. The idea is to wet the pig skin and then allow the pig to dry. The drying process is what helps cool the pig. Sprinklers should be used and not misters because misters may not wet pigs well. Pigs should be allowed to dry before sprinklers are reactivated. The amount of time required for pigs to dry will vary with different hot weather conditions. Pigs should be provided with a pen location where they can stay away from the sprinkler system.

Circulation fans are used to increase air movement at pig level. The increased air movement helps cool because of air movement and helps dry the pigs after being wetted by the sprinklers. Circulation fans do not really ventilate a building so they are not a substitute for a good summer ventilation system. Allowing the sidewall building opening to be close to the pig area helps keep pigs cool because it allows air to enter the building close to the pig area.

Specifications for Attic Ventilation and Opening Requirements

Attic ventilation needs to be provided to help cool the attic during summer conditions. Openings into the attic must be provided to allow air to enter the attic to adequately supply air for the inlets to ventilate the animal space. Generally, the openings required to supply air for ventilation of the animal space is adequate for providing attic ventilation.

Attic openings can only be provided in the gable ends of the building and along the ridge. No eave openings should be provided because any air leaving the animal space via the curtain in cold weather will cause attic moisture problems. The warm air will enter the attic through the eave opening, and the moisture will condense out of the warm air because the attic space will be colder. No reasonable amount of attic ventilation can compensate for warm, moist air entering an attic space in cold weather.

The amount of attic openings will depend upon the total fan ventilation rate of the building. The square feet of free attic opening area required is calculated by dividing the sum of all the fan ventilation in cfm by 200. Free attic opening area is the actual opening required. Most gable end louvers are about 50% effective; therefore, a 4 ft² gable louver would have 2 ft² of free opening area. A gable hood type detail can be constructed which can allow a large amount of free opening area to be provided while still protecting the attic space. Some ridge vents should always be used and also provide a path for air to enter the attic to supply ventilation air.

Specifications for Heater Requirements

Supplemental heat will be required at times in grow-finish facilities. However, the amount of time that the heater(s) will need to operate should not be very great. Heaters can be used during clean-up periods and to dry a room out before new pigs are placed. Also, if small pigs (50 lbs) are placed in a finishing room when the weather is very cold, the inside temperature cannot be maintained by the small pigs themselves. Some amount of supplemental heat may be required to maintain a 65 to 70 °F in a room with small pigs and the outside temperature is below 40 °F. When large pigs (< 100 lbs) are in a room, no supplemental heat should be required except in very cold weather. During very cold weather, the inside temperature could be allowed to decrease; however, pig performance may be hindered.

Heater sizes shown in Table 3 are given for rooms of various sizes. The given heater size is to maintain a 70 °F inside temperature in a room with 45 lb pigs when the outside temperature is 0 °F. If a larger heater than one shown in Table 3 is installed, heater efficiency will be reduced somewhat because of the over sizing.

Table 3. MO-Flex Grow-Finish Heater Requirements

<u>Total No. Pens</u>	<u>Total No. Pigs</u>	<u>Approximate Room Length in Feet</u>	<u>Heater Size Btu/hr</u>
8	160-200	40	48,000
10	200-250	52	62,500
12	240-300	60	72,000
14	280-350	72	86,500
16	320-400	80	96,000
18	360-450	92	110,500
20	400-500	100	120,000
22	440-550	112	134,500
24	480-600	120	144,000
26	520-650	132	158,500
28	560-700	140	168,000
30	600-750	152	182,500
32	640-800	160	192,000
34	680-850	172	206,500
36	720-900	180	216,000
38	760-950	192	230,500
40	800-1000	200	240,000
42	840-1050	212	254,500
44	880-1100	220	264,000
46	920-1150	232	278,500
48	960-1200	240	288,000

Plumbing and Electrical Information

Plumbing drawings are not included in the plan package. The exact water source for a building will be site specific. Since the source of fresh water and any filtering or treatment requirements for the building is unknown, plumbing drawings can not be developed for a general plan. Also, washing equipment requirements will be different for different brands and models and require different plumbing requirements. Washing equipment selection is left to the building owner. After knowing specific water source and washing equipment information, a plumbing plan can be developed.

Electrical drawings are not included in the plan package. Since specific equipment cannot be specified, electrical drawings cannot be developed. The exact electrical diagram requirements will depend upon the specific equipment selections and requirements. Additional information regarding electrical wiring is available from [Agricultural Wiring Handbook](#) (Hiatt, 1993), which covers wiring design issues, and [Farm Buildings Wiring Handbook](#) (Midwest Plan Service, 1992), which covers wiring installation issues.

ADDITIONAL RESOURCES

- ACI. 1989. Building Code Requirements for Reinforced Concrete and Commentary (ACI 318-89). American Concrete Institute. Detroit, MI.
- Ahrens, D. L. 1976. Concrete and Concrete Masonry. Hobar Publications. Division of Hobar Enterprises, INC. St. Paul, MN.
- AISC. 1989. Manual of Steel Construction, Allowable Stress Design, 9th Edition. American Institute of Steel Construction, Inc. Chicago, IL.
- Albright, L. D. 1990. Environment Control for Animals and Plants. ASAE Textbook No. 4. American Society of Agricultural Engineers. St. Joseph, MI.
- ASAE. 1990. STANDARDS 1990, Standards, Engineering Practices and Data, 37th Edition. American Society of Agricultural Engineers. St. Joseph, MI.
- ASCE. 1993. Minimum Design Loads for Buildings and Other Structures, ASCE 7-93. American Society of Civil Engineers. New York, NY.
- ASHRAE Handbook of Fundamentals. 1989. American Society of Heating, Refrigerating, and Air Conditioning Engineers, Inc. Atlanta, GA.
- Driggers, L. B. 1990. Ventilation of Swine Buildings Using the North Carolina Underslat Ventilation System. The North Carolina State Agricultural Extension Service. North Carolina State University. Raleigh, NC.
- Gustafson, R. J. 1988. Fundamentals of Electricity for Agriculture, 2nd Edition. American Society of Agricultural Engineers. St. Joseph, MI.
- Heber, A. J. 1995. "Mismatched Fans Throw Ventilation Out of Whack." National Hog Farmer. Vol. 40, No. 4. March 15, 1995.
- Hellickson, M. A. and J. N. Walker. 1983. Ventilation of Agricultural Structures. ASAE Monograph 6. American Society of Agricultural Engineers. St. Joseph, MI.
- Hiatt, R. S. 1993. Agricultural Wiring Handbook (Tenth Edition). National Food and Energy Council. Columbia, MO.
- Midwest Plan Service. 1983. Swine Housing and Equipment Handbook (MWPS-8). Midwest Plan Service. Ames, IA.
- Midwest Plan Service. 1983. Revised 1987. Structures and Environment Handbook (MWPS-1). Midwest Plan Service. Ames, IA.
- Midwest Plan Service. 1989. Farm and Home Concrete Handbook (MWPS-35). Midwest Plan Service. Ames, IA.

- Midwest Plan Service. 1989. Natural Ventilating Systems of Livestock Housing (MWPS-33). Midwest Plan Service. Ames, IA.
- Midwest Plan Service. 1990. Mechanical Ventilating Systems of Livestock Housing (MWPS-32). Midwest Plan Service. Ames, IA.
- Midwest Plan Service. 1990. Heating, Cooling and Tempering Air for Livestock Housing (MWPS-34). Midwest Plan Service. Ames, IA.
- Midwest Plan Service. 1992. Farm Buildings Wiring Handbook (MWPS-28). Midwest Plan Service. Ames, IA.
- Midwest Plan Service. 1994. Concrete Manure Storages Handbook (MWPS-36). Midwest Plan Service. Ames, IA.
- NDS. 1993a. NDS "National Design Specification for Wood Construction, Revised 1991 Edition." American Forest and Paper Association. Washington, DC.
- NDS. 1993b. NDS Commentary "Commentary on the National Design Specification for Wood Construction, Commentary on the 1991 Edition." American Forest and Paper Association. Washington, DC.
- NDS. 1993c. NDS Supplement "Design Values for Wood Construction, Revised Supplement to the Revised 1991 Edition." American Forest and Paper Association. Washington, DC.
- Parker, H. 1975. Simplified Engineering for Architects and Builders, 5th Edition. John Wiley & Sons, Inc. New York.
- Pork Industry Handbook. Purdue University Cooperative Extension Service. West Lafayette, IN.
- Truss Plate Institute (TPI). 1976. Bracing Wood Trusses: Commentary and Recommendations. BWT-76. Madison, WI.
- Truss Plate Institute (TPI). 1980. Handling and Erecting Wood Trusses: Commentary and Recommendations. HET-80. Madison, WI.
- Truss Plate Institute (TPI). 1991. Commentary and Recommendations for Handling, Installing and Bracing Metal Plate Connected Wood Trusses. HIB-91. Madison, WI.
- Walker, J. N. and F. E. Woeste. 1992. Post-Frame Building Design. ASAE Monograph 11. American Society of Agricultural Engineers. St. Joseph, MI.
- Wang, C. K. and C. G. Salmon. 1985. Reinforced Concrete Design, 4th Edition. Harper and Row, Publishers. New York.

A. Missouri Siphon Flush Tanks

Flushing is the preferred means of removing manure from MO-Flex Swine Buildings, and siphon flush tanks have attained preference as a water release device due to their simplicity and durability. A few commercially built siphons are available, and if properly sized and installed, work quite well. In Missouri, we have had considerable success with a "home-made" siphon design. Drawings are included in this plan to build MO Siphon Tanks as an integral part of the building structure. However, other water release devices can be used with MO-Flex Swine Buildings.

MO Siphon Tank Components

Although detailed knowledge of siphon operation is not necessary for construction of a siphon, a basic understanding of how a siphon works can help in judging its application and feasibility for a particular individual. The "Missouri" siphon tank consists of the following basic components as noted below and shown in figure 1.

1. Tank
2. Bell with Vent Hole
3. Discharge Pipe
4. Trigger Tube
5. Trap

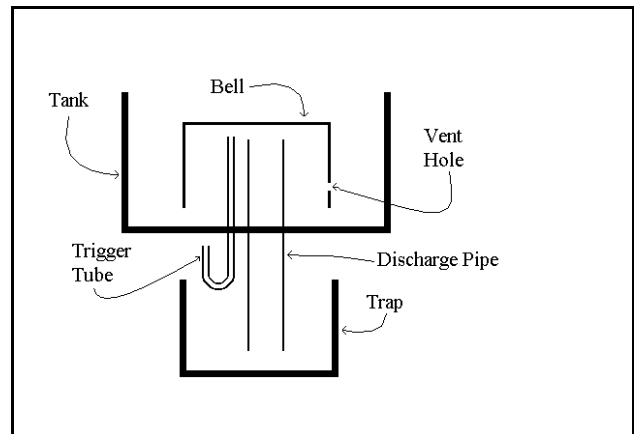

Figure 1. Siphon Tank Components

Siphon Tank Operation

The operational sequence of the Missouri Siphon Flush Tank is described in the following section. The simplicity of this siphon tank is realized by understanding the operation. No moving parts exist with the operation of the tank.

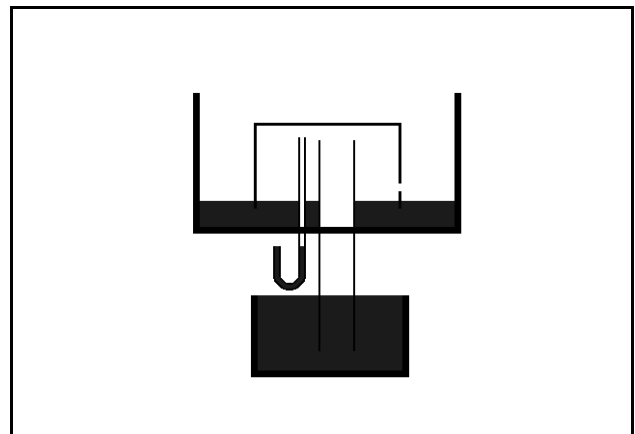

Figure 2. Beginning of Fill

The sequence of operation of the siphon tank begins with the tank filling with water as shown in figure 2. At the beginning of fill, subsequent to a prior flush, water occupies the shaded portions of the system. As the tank continues to fill, water covers the vent hole in the bell and a specific volume of air is trapped under the bell and in the discharge pipe. After the vent hole is covered, the water level under the bell rises at a slower rate than the water level in the tank. Also, the water levels in the discharge pipe and trigger tube are "pushed downward" by air pressure as water rises inside the bell.

Figure 3 shows the water levels in the various components of the siphon tank during the filling process. The water level in the tank will continue to rise faster than the water level under the bell. Also, the water levels will continue to drop in the trigger tube and discharge pipe until the tank is full.

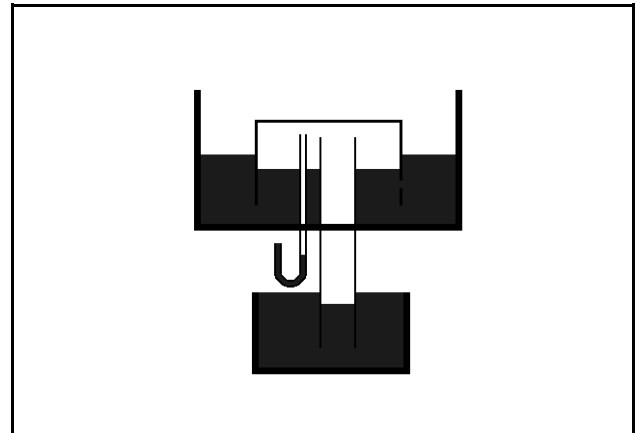

Figure 3. During the Fill

At the end of the fill cycle, water levels are as shown in the figure 4. At the end of fill, air is "pushed" around the bottom of the "U" in the trigger tube. This blows the remaining water out of the "up" leg of the trigger tube and allows the air to escape from under the bell. When air is purged from the system, water fills the area under the bell and the discharge pipe, and flow begins.

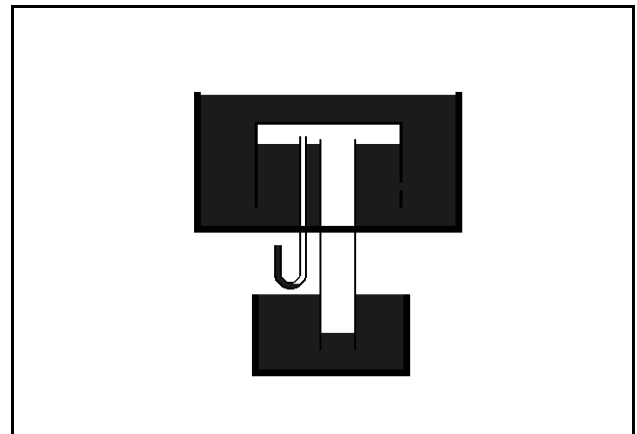

Figure 4. End of Fill

At the beginning and during flow water occupies the area under the bell as shown in figure 5.

After flow is established, the water level in the tank continues to drop until air enters the system underneath the bottom edge of the bell, and the siphon "breaks." Since the vent hole is exposed at this point, air is admitted into the bell until atmospheric pressure exists and conditions are correct for the next fill cycle as shown in figure 1. If properly installed, the trigger tube will refill with water during the tank discharge cycle as shown in figure 5.

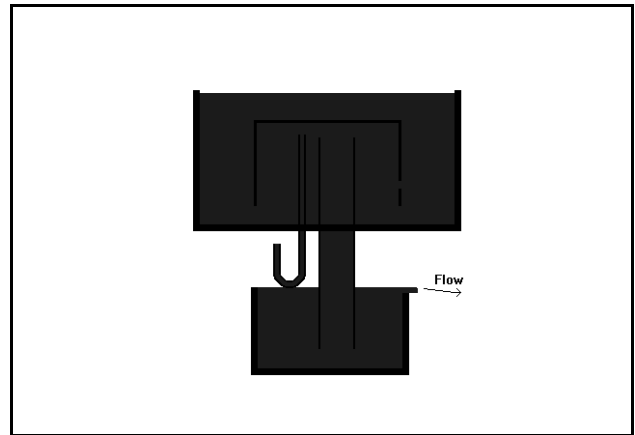

Figure 5. Beginning of Flow

By examining figures 1 through 5, one can ascertain that rather precise dimensions and construction/installation techniques are necessary in order to insure that the Missouri Siphon Flush Tank operates properly. Some of the parameters which are critical to siphon design and operations include:

1. Tank area in plan view and tank depth
2. Bell area in plan view and number of bells
3. Discharge pipe diameter and number of pipes
4. Trigger tube diameter
5. Depth of tank
6. Vent hole diameter and placement
7. Distance discharge pipe extends into tank
8. Distance discharge pipe extends into bell
9. Height of bell above bottom of tank
10. Length of "open" leg of trigger tube.

Siphon flush tanks **MUST** be built strictly according to plans to insure proper operation.

Siphon Tank Start-up Procedure

This start-up procedure insures that the tank will flush at the desired level by accounting for construction tolerances.

1. Make the "up" leg of the trigger tube 2" longer than indicated on the plan.
2. Fill trigger tube and sump. Then fill tank with fresh water to desired level and shut off water.
3. Drill ¼" holes in ¼" increments down from the top edge of the "up" leg of the trigger tube until tank flushes. For safety, use a cordless drill due to the wet environment.
4. Cutoff trigger tube pipe at last hole drilled when tank flushed.
5. Use fresh water during the start-up procedure.

B. Flush Gutter Water Trap

A water trap is required to isolate the air spaces and ventilation systems between adjacent rooms served by a common flush gutter. Different water trap designs are possible. A recommended flush gutter water trap is shown below.

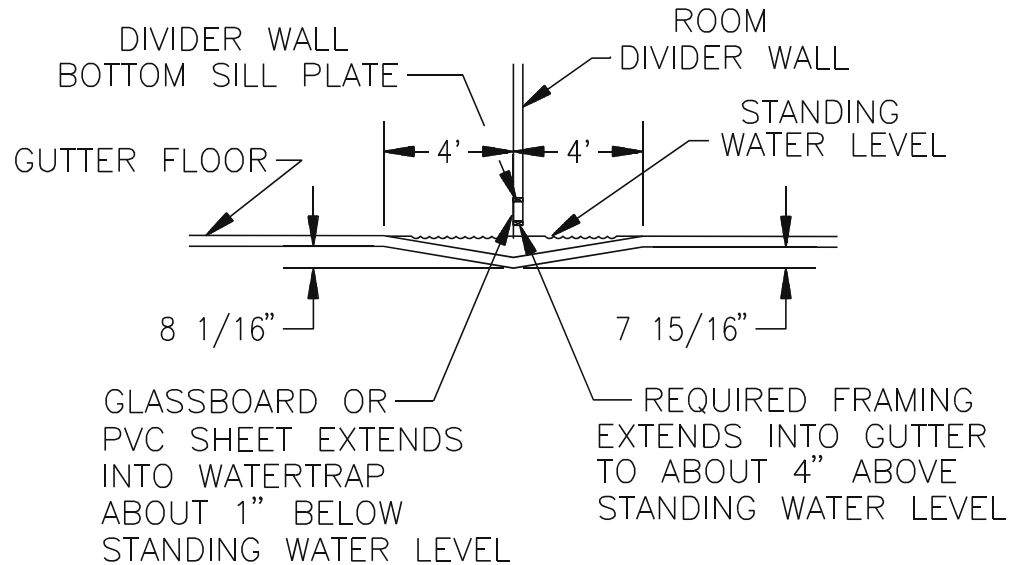

Figure 6. Scaled Sketch of Flush Gutter Water Trap

The above water trap isolates ventilation systems in adjacent rooms while allowing the flush water to pass under the interior partition wall (divider wall) from room to room. The isolation is accomplished by the glassboard extending about 1" into the standing water.

The glassboard is located on the "uphill" side of the divider wall and protects the wall from flush water splashing against the wall. The wall sill plate and the framing that extends the wall into the gutter channel should be constructed using CCA treated lumber. The gutter floor slope is continuous from one side of the trap to the other. Up to three of the above water traps can be placed in one continuous gutter.

If more than three traps are required, the flush volume should be increased to insure an adequate flush flow is maintained throughout the length of the gutter. The flush volume can easily be increased when using the MO Siphon Flush Tank by lengthening the flush tank length by 1' over the length of the tank recommended on the flush tank drawings (Sheets F5, F8 or F9).

C. Anaerobic Lagoon Systems

Anaerobic lagoon systems are a popular manure storage and treatment option for Missouri. Anaerobic lagoons are earthen structures that must be designed and built to meet Missouri Department of Natural Resources regulations. An anaerobic lagoon system is needed for use with flush and pit recharge manure handling and removal systems. A hairpin gutter manure system can also be used with an anaerobic lagoon.

PVC pipe is recommended to connect manure handling systems from building(s) to the anaerobic lagoon. A submerged inlet, shown in Figure 6, allows effluent to flow into an anaerobic lagoon without the potential of cold air entering a building through the drain line. A submerged inlet can help reduce odor potential from manure effluent draining from a building. A surface inlet, shown in Figure 7, can be used instead of a submerged inlet.

A recycle pump system will be required for both a flush and a pit recharge manure system. The recycle pump used for a recycle system should be a submersible, sewage ejector type of pump. A sewage ejector pump has larger impeller tolerances which allow the pump to operate longer between services. A wet well, shown in Figure 8, is located in the anaerobic lagoon bank to supply the recycle water. A wet well installation allows for easier maintenance of the recycle pump. To service the pump, one can simply lift the pump from the wet well instead of having to either drag the pump out of the lagoon or raft out onto the lagoon.

The build-up of salt crystals (struvite) is a common problem when using recycle systems. An acid cleaning system should be considered to help maintain any recycle system. Muriatic acid solution (a 10% hydrochloric acid) can be circulated through a recycle system to dissolve the struvite. If a wet well is used, the acid cleaning system can be relatively easily incorporated into the recycle system. An acid cleaning system generally consists of an acid storage tank and a small acid recycle pump. The acid recycle pump can be plumbed into the union of the recycle pipe that connects to the building(s), and a return line can be laid on the ground to return the acid back to the storage tank. The circulating acid will dissolve any salt build-up in the recycle line(s). If an acid recycle system is desired, the small stud frame building could store the acid recycle system.

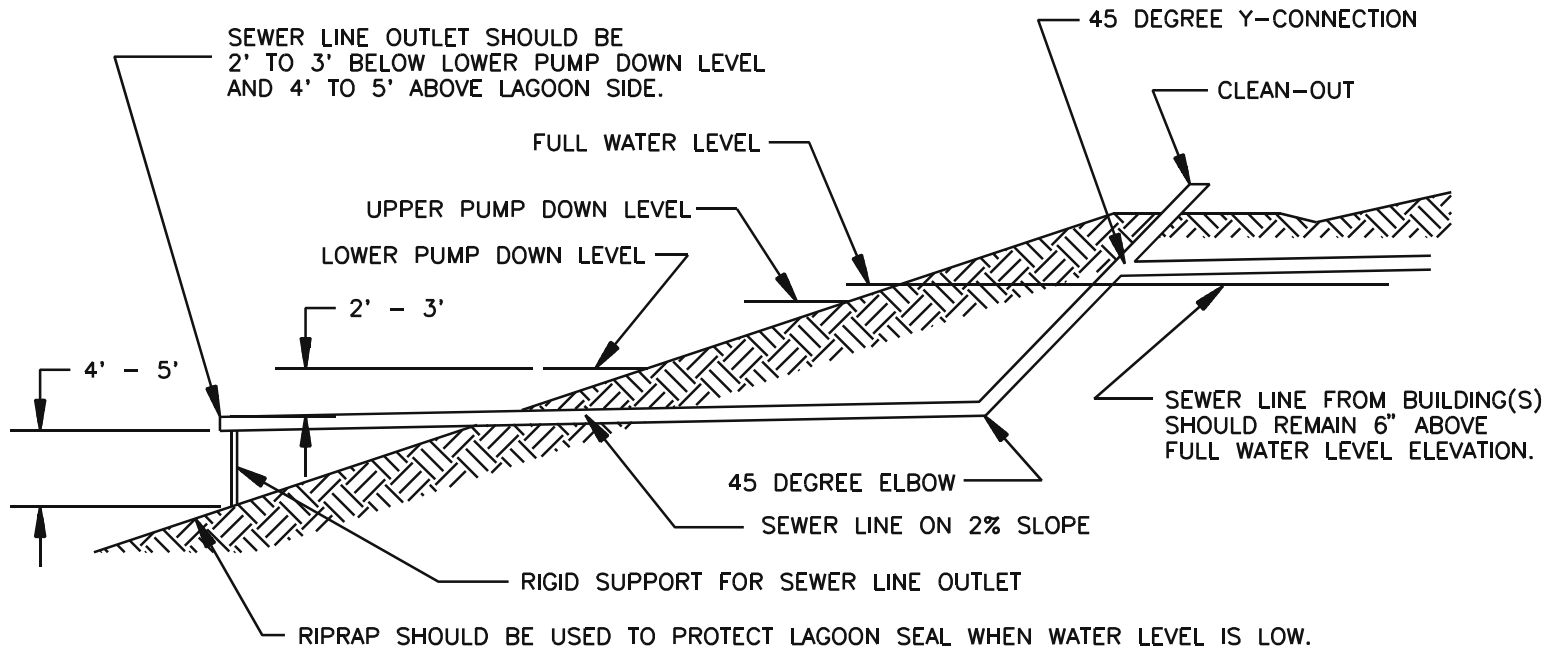

Figure 6. Scaled Sketch of Submerged Inlet into Anaerobic Lagoon.

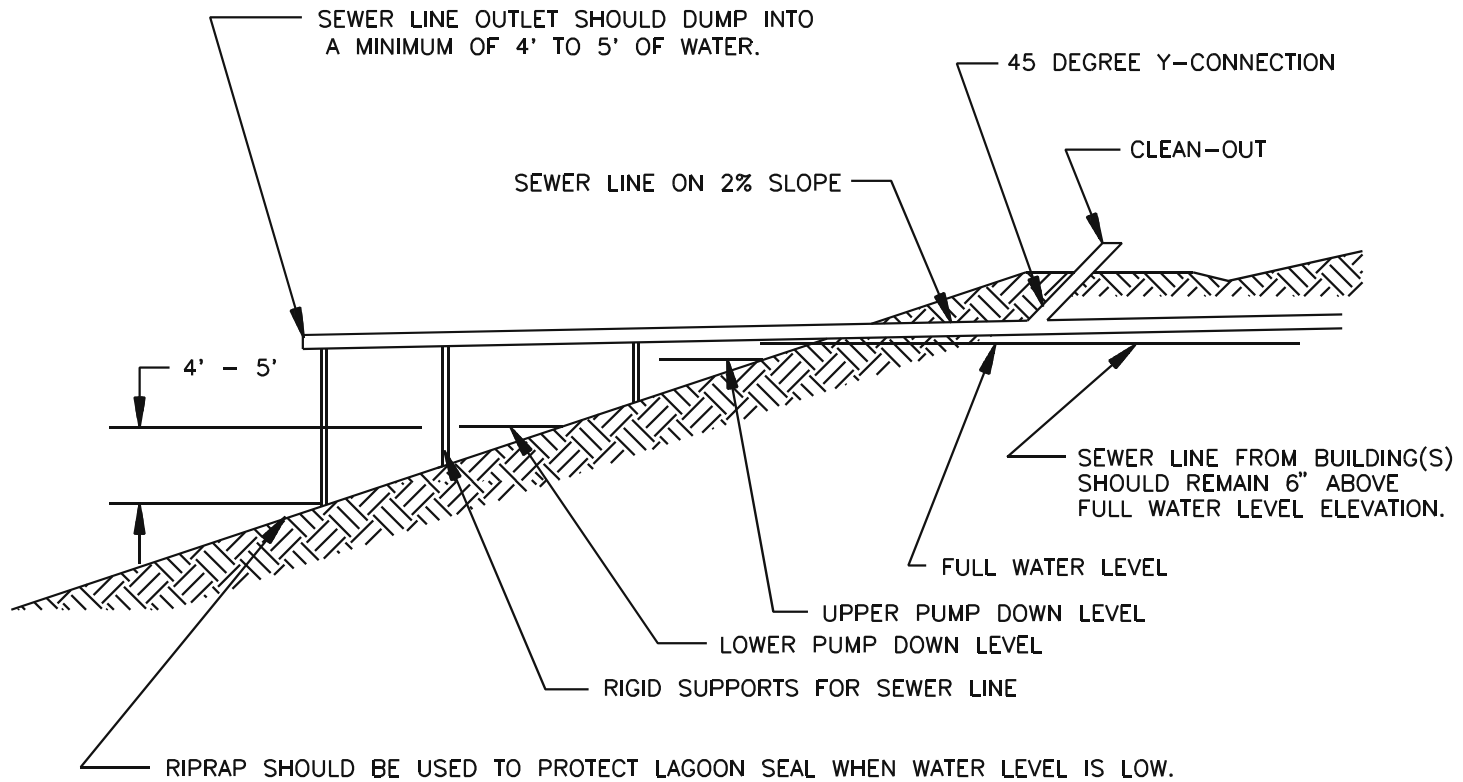

Figure 7. Scaled Sketch of Surface Inlet into Anaerobic Lagoon.

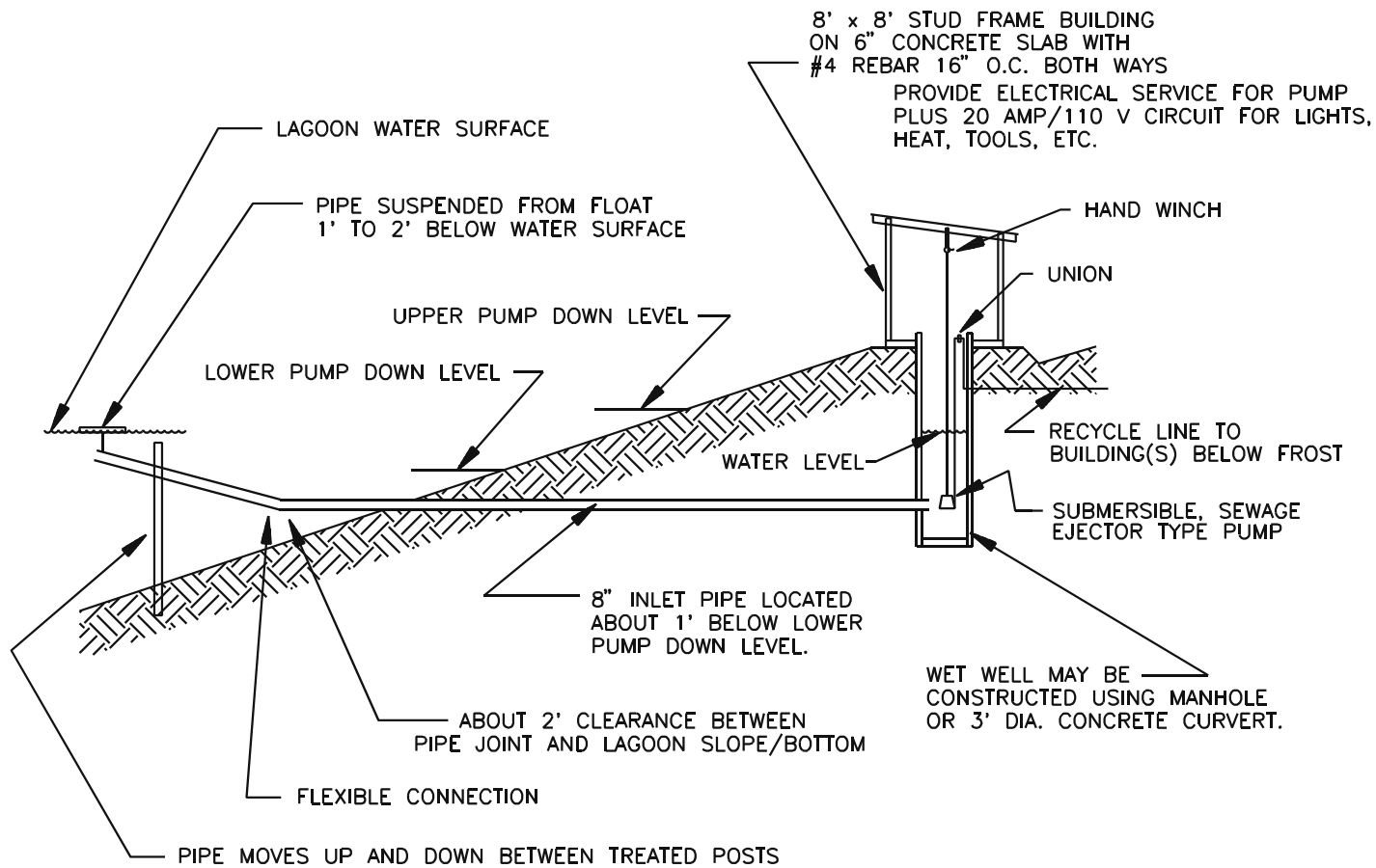

Figure 8. Scaled Sketch of Wet Well Installation for Lagoon Recycle Pump.

D. Concrete Manure Storages

The gravity drain gutter system allows for a liquid manure system. If the gravity drain gutter option is selected, an outside manure storage structure will be needed. Several types of structures are possible to serve as a liquid manure storage facility. Concrete manure storage facilities are probably the most common type of swine manure storage structure.

This MO-Flex Grow-Finish Building Plan does not have a manure storage plan included with the building plan. Information for designing and constructing concrete manure storages is available [Concrete Manure Storages Handbook \(MWPS-36\)](#). This handbook provides design criteria, reinforcing selection and construction details for liquid manure storages. However, local requirements and conditions may require specific design changes. A liquid manure storage should be certified by an engineer to insure that the structure will meet the required loads and comply with an environmental regulations.

E. Fan Sizes for Flat Ceiling with Flushing Option

The building option for these fan specifications uses a flat ceiling construction and the flush manure removal option (i.e. no pit ventilation). The exhaust fan performance specifications in this appendix are for rooms with pens ranging from 8 pens per room to 48 pens per room.

Flat Ceiling With Flush System				
No Pit Ventilation				
Pens/ Room ¹	Stage ¹	Typical Fan Diameter and Type	Minimum Operating Rate (cfm) ²	Maximum Operating Rate (cfm)
8	1	12" variable speed	480/600	1300
10	1	14" variable speed	600/750	1800
12	1	12" variable speed	720/900	1300
	2	14" single speed		1800
14	1	12" variable speed	840/1050	1300
	2	14" single speed		1800
16	1	16" variable speed	960/1200	2400
	2	16" single speed		2400
18	1	16" variable speed	1080/1350	2400
	2	16" single speed		2400
20	1	16" variable speed	1200/1500	2400
	2	16" single speed		2400
22	1	18" variable speed	1320/1650	3500
	2	18" single speed		3500
24	1	18" variable speed	1440/1800	3500
	2	18" single speed		3500
26	1	18" variable speed	1560/1950	3500
	2	18" single speed		3500

1. Rooms with 8 to 26 pens each can have all fans located in one fan bank.
2. The minimum operating rate (cfm) gives the 3 cfm minimum rate for a given room with a minimum or a maximum number of pigs.

Flat Ceiling With Flush System (continued)				
No Pit Ventilation				
Pens/ Room ¹	Stage ²	Typical Fan Diameter and Type	Minimum Operating Rate (cfm) ³	Maximum Operating Rate (cfm)
28	1	2-16" variable speed	840/1050	2400
	2	16" single speed		2400
30	1	2-16" variable speed	900/1125	2400
	2	18" single speed		3500
32	1	2-18" variable speed	1150/1200	3500
34	1	2-18" variable speed	1150/1275	3500
	2	18" single speed		3500
36	1	2-18" variable speed	1150-1350	3500
	2	18" single speed		3500
38	1	2-18" variable speed	1150/1425	3500
	2	18" single speed		3500
40	1	2-18" variable speed	1200/1500	3500
	2	24" single speed		5500
42	1	2-18" variable speed	1260/1575	3500
	2	24" single speed		5500

1. Rooms with 28 to 42 pens each should have the fans split into two fan banks with one stage 1 fan in each bank. The two fan banks should be located at the one-third points of the room length.
2. All fans in stage 1 should operate together. The stage 1 fans should operate at the same rate and can be (should be) controlled by the same controller/thermostat.
3. The minimum operating rate (cfm) gives the 3 cfm minimum rate for a given room with a minimum or a maximum number of pigs.

Flat Ceiling With Flush System (continued)				
No Pit Ventilation				
Pens/ Room ¹	Stage ²	Typical Fan Diameter and Type	Minimum Operating Rate (cfm) ³	Maximum Operating Rate (cfm)
44	1	3-16" variable speed	860/1100	2400
	2	24" single speed		5500
46	1	2-16" variable speed	800/1150	2400
		18" variable speed	1150	3500
	2	18" single speed		3500
48	1	2-16" variable speed	865/1200	2400
		18" variable speed	1150/1200	3500
	2	24" single speed		5500

1. Rooms with 44 to 48 each should have the fans split into three fan banks with one stage 1 fan in each bank. The three fan banks should be located at the one-fourth points of the room length.
2. All fans in stage 1 should operate together. The stage 1 fans should operate at the same rate and can be (should be) controlled by the same controller/thermostat.
3. The minimum operating rate (cfm) gives the 3 cfm minimum rate for a given room with a minimum or a maximum number of pigs.

Fan Selection Criteria: The fan performance static pressure is recommended to be 0.10" w.g. (water gauge) for all fans. The maximum operating rate (cfm) is a typical maximum rate for the typical fan diameter given in the fan column. The actual maximum operating rate (cfm) at 0.10" w.g. will vary between brands and models. Selected fans should be rated.

F. Fan Sizes for Flat Ceiling with Hairpin Gutter Option

The building option for these fan specifications uses a flat ceiling construction and the hairpin gutter manure removal option (i.e. pit ventilation). The exhaust fan performance specifications in this appendix are for rooms with pens ranging from 8 pens per room to 48 pens per room.

Flat Ceiling with Hairpin Gutter System				
Pit Ventilation Provides Minimum Rate for Small Pigs				
Pens/ Room ¹	Stage ¹	Typical Fan Diameter and Type	Minimum Operating Rate (cfm) ²	Maximum Operating Rate (cfm)
8	1	Pit System		600
	2	12" variable speed	640/800	1300
10	1	Pit System		750
	2	12" variable speed	800/1000	1300
12	1	Pit System		900
	2	14" variable speed	960/1200	1800
14	1	Pit System		1050
	2	16" variable speed	1200/1400	2400
16	1	Pit System		1200
	2	16" variable speed	1280/1600	2400
18	1	Pit System		1350
	2	16" variable speed	1440/1800	2400
20	1	Pit System		1500
	2	18" variable speed	1750/2000	3500
22	1	Pit System		1650
	2	18" variable speed	1760/2200	3500
24	1	Pit System		1800
	2	20" variable speed	2000/2400	4000
26	1	Pit System		1950
	2	20" variable speed	2080/2600	4000

1. Rooms with 8 to 26 pens each can have all fans located in one fan bank.
2. The minimum operating rate (cfm) gives an additional 4 cfm increase to minimum rate for a given room with a minimum or a maximum number of pigs.

Flat Ceiling with Hairpin Gutter System (continued)				
Pit Ventilation Provides Minimum Rate for Small Pigs				
Pens/ Room ¹	Stage ²	Typical Fan Diameter and Type	Minimum Operating Rate (cfm) ³	Maximum Operating Rate (cfm)
28	1	Pit System		2100
	2	2-16" variable speed	1200/1400	2400
30	1	Pit System		2250
	2	2-16" variable speed	1200/1500	2400
32	1	Pit System		2400
	2	2-16" variable speed	1265/1600	2400
34	1	Pit System		2550
	2	2-18" variable speed	1750	3500
36	1	Pit System		2700
	2	2-18" variable speed	1750/1800	3500
38	1	Pit System		2850
	2	2-18" variable speed	1750/1900	3500
40	1	Pit System		3000
	2	2-18" variable speed	1750/2000	3500
42	1	Pit System		3150
	2	2-18" variable speed	1750/2100	3500

1. Rooms with 28 to 42 pens each should have the fans split into two fan banks with one stage 2 fan in each bank. The two fan banks should be located at the one-third points of the room length.
2. All fans in same stage should operate together. The fans in same stage should operate at the same rate and can be (should be) controlled by the same controller/thermostat.
3. The minimum operating rate (cfm) gives an additional 4 cfm increase to minimum rate for a given room with a minimum or a maximum number of pigs.

Flat Ceiling with Hairpin Gutter System (continued)				
Pit Ventilation Provides Minimum Rate for Small Pigs				
Pens/ Room ¹	Stage ²	Typical Fan Diameter and Type	Minimum Operating Rate (cfm) ³	Maximum Operating Rate (cfm)
44	1	Pit System		3300
	2	2-16" variable speed	1200	2400
		18" variable speed	1750	3500
46	1	Pit System		3450
	2	2-16" variable speed	1200	2400
		18" variable speed	1750	3500
48	1	Pit System		3600
	2	2-16" variable speed	1200	2400
		18" variable speed	1750	3500

1. Rooms with 44 to 48 each should have the fans split into three fan banks with one stage 2 fan in each bank. The three fan banks should be located at the one-fourth points of the room length.
2. All fans in same stage should operate together. The fans in same stage should operate at the same rate and can be (should be) controlled by the same controller/thermostat.
3. The minimum operating rate (cfm) gives an additional 4 cfm increase to minimum rate for a given room with a minimum or a maximum number of pigs.

Fan Selection Criteria: The fan performance static pressure is recommended to be 0.10" w.g. (water gauge) for all fans. The maximum operating rate (cfm) is a typical maximum rate for the typical fan diameter given in the fan column. The actual maximum operating rate (cfm) at 0.10" w.g. will vary between brands and models. Selected fans should be rated.

G. Pit Ventilation Pipe Designs for Hairpin Gutters

The PVC pipe designs provided in this appendix are for the pit ventilation system of the hairpin gutter option. The hole spacing shown for each pipe length provides for even airflow removal from the pit for the entire length of the pipe. A ½" diameter drain hole should be drilled in the bottom of the PVC pipe at 10' intervals to allow any water that may enter the pipe to drain out.

The static pressure fan rating provided with each design is for the pipe only. An additional static pressure of 0.05" w.g. to 0.10" w.g. should be added to the static pressure rating in the table to select the fan. This additional static pressure is required because the building space above the pits will be operating at a negative pressure that the pit fan must overcome to ventilate the building. An optional manifold system could be incorporated into the pit system. If a manifold system is used, the static pressure losses due to the manifold must also be added to the static pressure rating used to select the fan for the pit system.

Design for 30' Pipe.

Fan Rating: 115 cfm @ 0.10 S.P. Pipe Size: 6" Pipe Length: 30' Hole Size¹: 1" @ 4 & 8 o'clock			
Location from fan ²	Distance from fan ³	Location from fan ²	Distance from fan ³
1	1' 1½"	8	16' 9½"
2	3' 5"	9	19' 0"
3	5' 8"	10	21' 2½"
4	7' 11"	11	23' 5"
5	10' 2"	12	25' 7½"
6	12' 4½"	13	27' 10"
7	14' 7"		

1. For a given location. Hole size gives the size of the 2 holes drilled at the 4 and 8 o'clock positions.
2. Locations from fan are the positions down the length of the pipe from the fan or the end of the gutter that has the fan.
3. Distance from fan or end of gutter with fan to the center of the holes.

Design for 40' Pipe.

Fan Rating: 150 cfm @ 0.10" S.P. Pipe Size: 6" Pipe Length: 40' Hole Size¹: 1½" @ 4 & 8 o'clock			
Location from fan ²	Distance from fan ³	Location from fan ²	Distance from fan ³
1	1' 4"	10	23' 4"
2	3' 11"	11	25' 8"
3	6' 6"	12	28'
4	9'	13	30' 4"
5	11' 5"	14	32' 8"
6	13' 10½"	15	35'
7	16' 3"	16	37' 4"
8	18' 7½"	17	39' 8"
9	21' 0"		

1. For a given location. Hole size gives the size of the 2 holes drilled at the 4 and 8 o'clock positions.
2. Locations from fan are the positions down the length of the pipe from the fan or the end of the gutter that has the fan.
3. Distance from fan or end of gutter with fan to the center of the holes.

Design for 50' Pipe.

Fan Rating: 190 cfm @ 0.10" S.P. Pipe Size: 8" Pipe Length: 50' Hole Size¹: 1" @ 4 & 8 o'clock			
Location from fan ²	Distance from fan ³	Location from fan ²	Distance from fan ³
1	1' 2"	12	26' 5½"
2	3' 6"	13	28' 8½"
3	5' 10"	14	31' 0"
4	8' 2"	15	33' 3"
5	10' 6"	16	35' 6"
6	12' 9½"	17	37' 9"
7	15' 1"	18	40' 0"
8	17' 4½"	19	42' 3½"
9	19' 7½"	20	44' 6½"
10	21' 11"	21	46' 10"
11	24' 2"	22	49' 1"

1. For a given location. Hole size gives the size of the 2 holes drilled at the 4 and 8 o'clock positions.
2. Locations from fan are the positions down the length of the pipe from the fan or the end of the gutter that has the fan.
3. Distance from fan or end of gutter with fan to the center of the holes.

Design for 60' Pipe.

Fan Rating: 225 cfm @ 0.10" S.P. Pipe Size: 8" Pipe Length: 60' Hole Size¹: 1" @ 4 & 8 o'clock			
Location from fan ²	Distance from fan ³	Location from fan ²	Distance from fan ³
1	1' 1½"	15	31' 5½"
2	3' 5"	16	33' 6½"
3	5' 7½"	17	35' 8"
4	7' 10"	18	37' 9"
5	10' 1"	19	39' 10"
6	12' 3"	20	41' 11½"
7	14' 5"	21	44' ½"
8	16' 7"	22	46' 1½"
9	18' 9"	23	48' 2½"
10	20' 10½"	24	50' 4"
11	23' 0"	25	52' 5"
12	25' 1½"	26	54' 6"
13	27' 3"	27	56' 7"
14	29' 4½"	28	58' 8"

1. For a given location. Hole size gives the size of the 2 holes drilled at the 4 and 8 o'clock positions.
2. Locations from fan are the positions down the length of the pipe from the fan or the end of the gutter that has the fan.
3. Distance from fan or end of gutter with fan to the center of the holes.

Design for 70' Pipe.

Fan Rating: 265 cfm @ 0.10" S.P. Pipe Size: 8" Pipe Length: 70' Hole Size¹: 1½" @ 4 & 8 o'clock			
Location from fan ²	Distance from fan ³	Location from fan ²	Distance from fan ³
1	1' 4"	16	37' 3"
2	3' 11"	17	39' 6"
3	6' 6"	18	41' 8½"
4	9' ½"	19	43' 11½"
5	11' 6"	20	46' 2"
6	14' 0"	21	48' 5"
7	16' 5"	22	50' 7½"
8	18' 9½"	23	52' 10"
9	21' 2"	24	55' ½"
10	23' 6"	25	57' 3"
11	25' 10"	26	59' 6"
12	28' 2"	27	61' 8½"
13	30' 5½"	28	63' 11"
14	32' 8½"	29	66' 1½"
15	35' 0"	30	68' 4"

1. For a given location. Hole size gives the size of the 2 holes drilled at the 4 and 8 o'clock positions.
2. Locations from fan are the positions down the length of the pipe from the fan or the end of the gutter that has the fan.
3. Distance from fan or end of gutter with fan to the center of the holes.

Design for 80' Pipe

Fan Rating: 300 cfm @ 0.10" S.P. Pipe Size: 10" Pipe Length: 80' Hole Size¹: 1" @ 4 & 8 o'clock			
Location from fan ²	Distance from fan ³	Location from fan ²	Distance from fan ³
1	1' 2½"	19	42' 8"
2	3' 6½"	20	44' 11½"
3	5' 11"	21	47' 2½"
4	8' 3"	22	49' 5½"
5	10" 7½"	23	51' 8½"
6	12" 11½"	24	53' 11½"
7	15' 3"	25	56' 3"
8	17' 7"	26	58' 6"
9	19" 10½"	27	60' 9"
10	22' 2"	28	63'
11	24' 6"	29	65' 3"
12	26' 9½"	30	67' 6"
13	29' ½"	31	69' 9"
14	31' 4"	32	72'
15	33' 7½"	33	74' 3½"
16	35' 10½"	34	76' 6½"
17	38' 2"	35	78' 9½"
18	40' 5"		

1. For a given location. Hole size gives the size of the 2 holes drilled at the 4 and 8 o'clock positions.
2. Locations from fan are the positions down the length of the pipe from the fan or the end of the gutter that has the fan.
3. Distance from fan or end of gutter with fan to the center of the holes.

Design for 90' Pipe.

Fan Rating: 340 cfm @ 0.10" S.P. Pipe Size: 10" Pipe Length: 90' Hole Size¹: 1" @ 4 & 8 o'clock			
Location from fan ²	Distance from fan ³	Location from fan ²	Distance from fan ³
1	1' 1½"	22	46' 8"
2	3' 5"	23	48' 9½"
3	5' 8"	24	50' 10½"
4	7' 11"	25	53' 0"
5	10' 1½"	26	55' 1"
6	12' 4½"	27	57' 2"
7	14' 7"	28	59' 3"
8	16' 9"	29	61' 4"
9	18' 11½"	30	63' 5"
10	21' 1½"	31	65' 6"
11	23' 3½"	32	67' 7½"
12	25' 5½"	33	69' 8½"
13	27' 7"	34	71' 9½"
14	29' 9"	35	73' 10½"
15	31' 10½"	36	75' 11½"
16	34' 0"	37	78' ½"
17	36' 1½"	38	80' 1½"
18	38' 3"	39	82' 2½"
19	40' 4½"	40	84' 3½"
20	42' 5½"	41	86' 4½"
21	44' 7"	42	88' 5½"

1. For a given location. Hole size gives the size of the 2 holes drilled at the 4 and 8 o'clock positions.
2. Locations from fan are the positions down the length of the pipe from the fan or the end of the gutter that has the fan.
3. Distance from fan or end of gutter with fan to the center of the holes.

Design for 100' Pipe.

Fan Rating: 375 cfm @ 0.10" S.P. Pipe Size: 10" Pipe Length: 100' Hole Size¹: 1" @ 4 & 8 o'clock			
Location from fan ²	Distance from fan ³	Location from fan ²	Distance from fan ³
1	1' 1½"	26	52' 4½"
2	3' 4"	27	54' 3½"
3	5' 6"	28	56' 3"
4	7' 8"	29	58' 2½"
5	9' 10"	30	60' 1½"
6	11' 11½"	31	62' 1"
7	14' 1"	32	64' 0"
8	16' 2½"	33	65' 11½"
9	18' 3½"	34	67' 10½"
10	20' 4½"	35	69' 9½"
11	22' 5"	36	71' 9"
12	24' 6"	37	73' 8"
13	26' 6"	38	75' 7"
14	28' 6½"	39	77' 6"
15	30' 7"	40	79' 5"
16	32' 7"	41	81' 4½"
17	34' 7"	42	83' 3½"
18	36' 7"	43	85' 2½"
19	38' 7"	44	87' 1½"
20	40' 7"	45	89' ½"
21	42' 6½"	46	91' 0"
22	44' 6"	47	92' 11"
23	46' 6"	48	94' 10"
24	48' 5½"	49	96' 9"
25	50' 5"	50	98' 8½"

1. For a given location. Hole size gives the size of the 2 holes drilled at the 4 and 8 o'clock positions.
2. Locations from fan are the positions down the length of the pipe from the fan or the end of the gutter that has the fan.
3. Distance from fan or end of gutter with fan to the center of the holes.