

Shock-chlorinating your well

Procedure for 6-inch diameter water wells.

The procedure for cleaning and sanitizing a water well and plumbing system with chlorine is called shock chlorination. Shock chlorination kills disease-causing organisms and controls nuisance problems, such as iron bacteria and hydrogen sulfide. Treatment should be done any time construction or repair work is done on the plumbing system, if flood or surface water gets into the well, or if a Department of Health water test for bacteria indicates "unsatisfactory" levels of coliform bacteria.

Follow the steps below to kill the bacteria and reduce the risk of reinfection.

1. Look in your yard, basement or well house for a 6-inch diameter rusty pipe sticking up out of the ground. Newer wells look similar to Figure 1 and older wells look similar to Figure 2. Gather whatever information you can about the well, such as age, actual diameter, total depth, casing depth, and standing water level. The well driller, pump installer or previous landowner can be sources of this information.

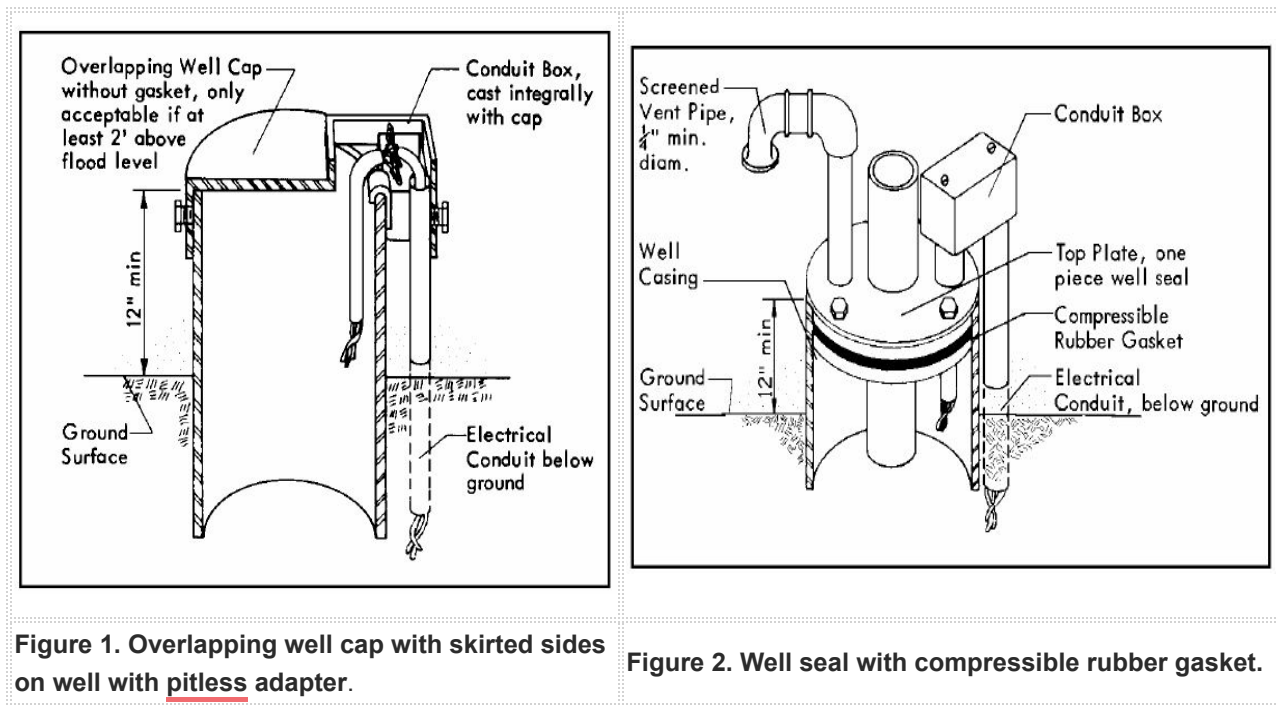

2. Remove the well cap by loosening the screws (if like Fig. 1) or unscrew the vent pipe (if like Fig. 2). Thoroughly scrub all accessible surfaces of the well and well house, using 1/2 gallon unscented chlorine (laundry) bleach per 5 gallons of water. Check the bleach label to be sure it contains 5.25 percent sodium hypochlorite. Wear rubber gloves and goggles to protect your skin from irritation. Rinse everything with clean water.
3. In a clean plastic 5-gallon bucket, add chlorine bleach at a rate of 1 pint of bleach per 25 feet of water depth in the well, then mix by filling the bucket with water. For example, a 250-foot deep, 6-inch diameter house well with a water level of 100 feet would require 6 pints (3/4 gallon) of bleach to treat the 150-foot column of water in the well. Pour the mixture down the well hole. Or if the well is deep, drop in 1/2 lb. of the small 65-75% calcium hypochlorite (swimming pool chlorine) tablets per 150 feet of water depth in the well.

4. Connect a garden hose to a nearby faucet and wash down the inside of the well. Let the water run until a strong chlorine odor comes out the hose. Shut off that faucet, then one by one, open all other faucets and flush toilets in your plumbing system until they smell of chlorine. If a strong odor is not detected, add more chlorine to the well. Chlorinate water softeners and iron or sand filters according to the manufacturer's directions. Don't chlorinate carbon or charcoal filters because it will use up their capacity.
5. Replace the well cap or vent pipe. Let the chlorinated water stand in the system at least 12 hours, to give the chlorine time to kill the bacteria. After this waiting period, turn on the faucets to flush the system of remaining chlorine. Start with outside faucets first to avoid overloading the septic system. Let the water run until there is no detectable chlorine odor.
6. Retest for bacteria after 7-10 days of use. If the well fails two consecutive tests, continuous disinfection may be necessary. Keep all test results with your important papers to document changes over time.

If you have specific questions about treating your water supply, refer to MU Extension publication EQ102, [Bacteria in Drinking Water](#). Sample bottles for testing for bacteria are available from the environmental public health specialist at your county [Health Department](#).