



Missouri 4-H

Horse Show Guide



Extension
University of Missouri



Table of Contents

- Horse Show Guidelines
 - Eligibility
 - Ownership, training, and management
- General Rules
- Attire, Tack, and Bits
- Class Guidelines
 - Showmanship
 - Horsemanship
 - Hunt Seat Equitation
 - Saddle Seat Equitation
 - Western Pleasure
 - Hunter Under Saddle
 - Non-Stock Type Class
 - Non-Stock Type Western Pleasure
 - Non-Stock Type English Pleasure
 - Ranch Riding Pleasure
 - Trail
 - In-hand Trail
 - Ranch Trail
 - Ranchmanship
 - Reining
 - Gaited Horse Pleasure
 - Pony Cart
 - Speed Events
 - Barrel Racing
 - Pole Bending
- [Missouri 4-H Horse Enrollment Form](#)

Missouri 4-H Horse Shows

4-H horse shows are more than competition; they are another tool we use in youth development. The purpose is to give members the opportunity to demonstrate what they know, to learn new skills and to develop friendships and memories that will last forever.

There are many opportunities for youth to engage in competition with their horses from local saddle club fun shows to national level breed competitions. 4-H is about skill development, sportsmanship, and leadership, not about winning. You as the project leader/parent are the key to instilling this philosophy if you believe so will your member/child. If your attitude is “Be the best you can be” and “make the best better” the member will have a fun learning experience.

1. The following are the guidelines for participation in 4-H horse shows. 1. Each member meets any guidelines as set by the state program and their county 4-H council. You must bring your 4-H [Horse Enrollment form](#), which was completed and a copy sent to your Extension office by May 1 to the show. You must have both your club leaders and project leader’s signature updated through the month that you are showing.
2. You must provide a current (within one year) Coggins test result form for each horse you will exhibit. This is a state law.

Missouri 4-H Horse Show Guidelines

Mission of 4-H

The Mission of 4-H Youth Development Programs is to create environments in which young people are valued, contributing members of their communities. The Missouri 4-H Horse Show Guidelines were developed by the Missouri 4-H Equine Advisory Council to help ensure safe and fair participation in the 4-H horse program.

Objectives

4-H horse shows in Missouri are designed for the development of the youth; therefore, it is intended that they provide opportunities for 4-H members to:

1. Develop leadership, initiative, self-reliance, sportsmanship, and other desirable characteristic traits.
2. Have fun and enjoy the recreation provided by riding and showing horses.
3. Learn skill and horsemanship.
4. Achieve knowledge of breeding, feeding, training, and management of horses.
5. Develop an ability to judge horses.
6. Increase awareness of safety precautions to prevent injury to themselves, others, and their mounts.

Eligibility

Membership

Each exhibitor must be enrolled by May 1 of the show year in a 4-H horsemanship project. Exhibitors must have a [Horse Enrollment Form](#) for each horse to be shown on file at the County Extension office by May 1. Members are to keep a copy of this form in their possession. Each exhibitor must be a member in good standing within his or her local program. Each member is to provide proof of eligibility in the form of a Horse Enrollment Form with the appropriate signatures when registering at a 4-H show. Failure to provide this form along with the Coggins report can result in refusal by the show management to allow participation.

4-H Age

Each exhibitor must have passed his or her eighth birthday and not have passed his or her nineteenth birthday before January 1 of the current year. The age on January 1 is the age for the entire year.

Ownership, Training and Management

Exhibitors must own or lease all horses they are showing beginning not later than May 1 of current year. Horses, which are not owned by the 4-H member(s), must have a lease agreement on file (on the back of the Project Horse Enrollment form). Horses shall not receive professional training, showing, or handling after May 1 of the current year. Riders may receive professional riding lessons; however, the trainer/instructor is not to train the horse. Training is defined as schooling the horse, not as assistance in clipping, loading into the trailer or assistance with potentially dangerous situations. Safety is of the utmost importance and the 4-H program recognizes that members will need occasional assistance. Ongoing behavior problems that require trainer assistance are considered training and will result in disqualification as a 4-H project horse. A project horse may be shared by siblings living in the same household, however that horse must be enrolled as a project horse for each member who uses it. Parents/guardians and the member should determine the extent a member shares “with the family” showing, management and care for their horse project based on the member’s age, available time, family resources, riding ability, physical limitations, etc. Please consult and follow “day of the show” management rules. Ideally, as the parents, project leaders, members, and extended family work together with the project; the primary emphasis is to help the member improve leadership and sportsmanship

skills: have fun and enjoy the recreation provided by riding and showing horses; learn work skills while achieving knowledge of breeding, feeding, training, and management; increasing awareness of safety precautions to prevent injury to themselves, others, and their mounts.

- First Example: Joe 4-Her’s parent rides Joe’s horse in circuit shows on weekends and Joe rides the same horse in 4-H. Who decides if this is the best management practice to help develop the member’s skills in training, feeding, showing, etc., the 4-H Youth Development Staff or the parent? Answer: The parent.

- Second Example: 4-H County X has a rule that members must warm up their own horse the day of the show. A parent has been riding all spring in circuit shows and for safety reasons, decides to tune up the spirited horse on the fairgrounds the day of the show for his 12 years old. Is this allowed? No. The local rules say members, not parents, are allowed to warm up horses the day of the show while on the grounds.
- Third Example: A first year member and his grandpa are lunging the horse the day of the show. Grandpa starts off holding the lunge line and passes it to the inexperienced member. While the rules say members must warm up their own horse there has to be common sense used to find the balance between helping and teaching a child and doing all the work for them. Should the committee disqualify grandpa for assisting an inexperienced member? No.
- Fourth Example: 4-H parent, Marion, calls with a concern that trainer, Marvin, who also has kids in the 4-H program, is riding/training little Marvin's horse and it is after May 1. The rule says, "Horses shall not receive professional training, showing or handling after May 1 of the current year". This is a gray area and ultimately parents will have to decide their course of action. Program tip: Parents need to assist their children without doing the work for them. As parents/guardians, you decide when you cross the line. Think about this, if you were a professional cake decorator would it be right for you to make the cake for your child to show at the fair? If you do all the work, what will the child learn?
- Fifth Example: Barb is a professional trainer and she and her daughter, Mindy, co-show a horse in the breed horse circuit. Can Mindy ride the horse in 4-H even though it has been ridden by a professional? Yes, because being a parent/guardian supersedes being a professional trainer. Can a 4-Her co-ride a horse with a professional trainer who is not a part of the immediate family? No, you can take lessons and receive help from a professional but it is not fair to everyone else to have a professional trainer showing your horse. Again, it is going to be the parent/guardians' call to do the right thing to help their child. Regardless that you are a professional trainer or not, if you are doing the most of the training without the member involved, there might be a problem.

Closing thoughts: There are important life lessons when members get the ribbon they earn, even when it is a white. "Good judgment comes from experience, and a lot of that comes from bad judgment" -Will Rogers. Helping youth sometimes means we have to let them fail and then talk about what could be done to improve next time. Remember, in 4-H we strive for blue ribbon kids, not blue-ribbon horses!

1. Warming up or training of horses by anyone other than the project member enrolled on that horse is prohibited on the show grounds. Violations of this rule are subject to disqualification from the show.
2. A project horse may be shown by more than one family member, at County and Regional Shows, as long as that horse is enrolled as a project horse for each member. Check the State Fair Horse Show rules, they may have different requirements.

Certification

The 4-H Project Leader has the responsibility of certifying that membership; age and management requirements are met.

General Rules

Infraction of any rule is subject to disqualification from the show. The show committee's decision is final. Any question or complaint of the judge's decision or procedure shall be directed to the attention of the ringmaster. The ringmaster shall act as a mediator between the judge and the exhibitor. It is considered improper to approach the judge before or during a show; but one may discuss matters with the judge after the show if the judge is willing and has the time. The judge shall be guided by the current ARHA rules for ranch horse classes, AQHA rules for other stock horse classes, showmanship, horsemanship, hunt seat equitation, trail, and reining classes, APHA (Paint) rules for trail in hand classes, Pinto Horse Association for pony driving classes, and non-stock type classes are guided by the Saddlebred, Arabian, Foxtrotter versatility, and Paso Fino breed rules. The judge, at his or her discretion, may refuse entry into the arena or remove an entry from a class for improper attire, equipment, and/or an unsound animal.

The rules for the Missouri State 4-H horse project are a compilation from the rule books of the major breed organizations. Please refer to these rule books and the materials outlined in this guide.

Please familiarize yourself with these rules. It is the responsibility of the 4-H exhibitor to know these rules.

Concerns about infractions of the rules should be addressed in writing to the show committee. Concerns that cannot be resolved should be submitted in writing to the State 4-H Specialist in charge of 4-H

Horsemanship Programs who will either make a decision based on the rules or refer the complaint to the grievance committee.

- Missouri 4-H does not condone the use of illegal and/or performance altering drugs, mechanical devices or artificial appliances or inhumane treatment of animals at 4-H sanctioned events. For complete information on what is considered inappropriate behavior, refer to AQHA rule 441 on Prohibited Conduct. Each member and/or parent is responsible for reading this rule and complying with it in all 4-H sanctioned events. Infractions of this rule may result in disqualification from the current and all future 4-H horse shows.
- A pony is defined as being 58" and under. A horse is defined as being over 58 inches.
- Novice is defined as exhibitors in their first or second year of the horsemanship project.
- Breaking to a lope in walk-trot novice classes (all speed and performance) will result in disqualification.
- Warming up or training of horses by anyone other than the project member enrolled on that horse is prohibited on the show grounds. Adults should not ride horses during 4-H horse project meetings or 4-H shows. Adults may not be covered by University of Missouri insurance. Violations of this rule are subject to disqualification from the show.

Ethics and Etiquette

The dictionary defines ethics as “the study of human conduct, with emphasis on the determination of right and wrong.” Ethics are concerned with voluntary actions; that is, the things you choose to do. The decisions you make regarding your horse and showing events affect how others view you, and reflect on your club, your county, and the 4-H program as a whole. Be sure the decisions you make are ethical ones.

To help determine whether what you are doing is ethical, ask yourself the following questions:

- Will I need to lie about this?
- Does this harm the horse?
- Is this against any rule?
- If someone were watching me, would I not do this?
- Does this misrepresent me or the horse?
- Would I be unhappy if someone did this to me?

If the answer to any of these questions is “yes,” do not do it. It is not ethical. To maintain your integrity and that of the 4-H Horse program, follow these guidelines:

- Obey the rules.
 - Rules are made for a reason, and they are meant for everyone to follow. Do not look for loopholes or ways to end or stretch the rules. Play fair. Be sure you know the rules of the show, your county, and your state.
- Be honest.
 - Any time you have to lie, you are being unethical. Do not lie, and do not do anything that you would later want to lie about or hide.
- Take proper care of your horse.
 - Make sure your horse has adequate food, water, and shelter and keep it in good health with correct grooming, parasite control, vaccinations, foot and dental care, and basic safety. Proper care also means that you use humane training methods. Any mistreatment or abuse is unacceptable and will not be tolerated by the 4-H program.
- Demonstrate good sportsmanship.
 - Good sportsmanship is part of being ethical. Be gracious and courteous whether you win or lose. Help others who are in the competition with you. Do not run down other members, and do not blame the judge for your performance. Never blame your horse if you do not do well. Jerking on the reins or spurring the horse in anger are poor images to project of yourself and 4-H. Your attitude is important not only in the show ring, but in all aspects of life.
- Keep competition in perspective.
 - Winning is not the main goal. Rather, strive to do your best, to learn, and to grow. Compete against yourself and the course instead of other members. Have fun.
- Maintain proper adult involvement.

- Remember that the main goal of 4-H is youth development. Parents and other adults are there to help and teach you, not to do your work. Help them to focus on what is best for all the kids and the program, not just on you. Do as much as you can yourself.

Warm-up Arena Etiquette

At a horse show, you will have opportunities to use warm-up space. The warm-up ring is usually overcrowded, so following these simple rules can help make it a safer and more beneficial place.

- All horses work in the same direction.
- Trainers, leaders, and helpers remain outside the arena.
- Do not mix carts and mounted horses in the same arena.
- Do not mix longeing and riding in the same arena.
- If you ride a mule, donkey, or pony, remember that some horses are not familiar with these kinds of animals and may be frightened. Be respectful and careful when warming up together.
- Do not cut others off into the rail or crowd the rail, moving others off.
- Communicate with those around you, especially if you are having trouble.
- Do not halt and/or back up without warning those around you.
- Keep two horses' lengths between you and the horses to the side, front, and back.
- Be in control; if you are not, you are not ready to be there.
- Keep your language and comments appropriate.
- The 4-H Code of Conduct applies at all times.
- If your horse has a tendency to kick, put a red ribbon in its tail.

In the Show Ring

Remember that all contestants are doing their best to be seen by the judge. Be respectful of the riders around you. Adhere to the same guidelines in the show ring as in the warm-up arena, and add the following:

- Do not try to "squeeze" into a space in line where there is not space.
- Do not be afraid to enter the arena first.
- When working a pattern, stay away from those who are lined up whenever possible.
- Be ready and waiting for the judge's signal for you to begin.
- Wait for the judge to acknowledge you before you begin your pattern and before returning to line when you finish your pattern unless the judge requests otherwise.
- Be sure your exhibitor number is clearly visible.
- If you are too close to another exhibitor, do not hesitate to circle safely and find your own space on the rail.
- Do not dismount in riding classes.
- Ask a steward or judging for permission if you want to be excused.
- Be sure your horse is prepared for the horse show environment (clapping, chairs moving, people climbing bleachers, and so on).

State Fair Sponsored 4-H/FFA Horsemanship Show

The State Fair Sponsored 4-H/FFA Horsemanship show is not a 4-H sponsored show, it is an affiliated show which is sponsored by the Department of Agriculture, State Fair Division and open to 4-H/FFA members. 4-H and FFA members are currently the only youth organizations eligible to participate. In 2001, FFA petitioned for participation and it was granted to allow them to the show in 2002 by the State Fair Director. 4-H eligibility to show in this opportunity is consistent with current 4-H rules which means they must be in good standing. This includes turning in their horse member enrollment form by May 1 and including a copy of the signed form with their entry. Members cannot participate if they are under age 8.

Show fees paid by exhibitors recover the show expense including staff, judges, ribbons, plaques, and facilities. The Department of Ag, State Fair Division contracts with the show superintendent, judges, and staff. The State Fair also contracts with 3 EMT's to be at the shows in case of personal injury. If animal health issues arise, it is the responsibility of the exhibitor to contact veterinarians and pay for treatment. State Fair has phone numbers to call for vet services. This animal health policy is consistent for all of the SF shows including the livestock shows held during the fair. While there is often a State Veterinarian on grounds, they inspect animals in a regulatory capacity.

The superintendent has a committee of show assistants that meet annually to review the rules and classes. As a way to obtain feedback for improvement, a suggestion box is available in the show office during the event and suggestions may be emailed or called into the show superintendent any time.

Attire, Tack, AND Bits

A-1

Exhibitors are required to exhibit their numbers in a fashion that makes it easy to read. If given two numbers they should be pinned on each side of the saddle blanket. If given one number, it should be pinned on the exhibitor's back. Halter or showmanship exhibitors will display the number on the back. Saddle seat riders will show the number on the back (). Failure to display a correct number in judged classes will result in disqualification.

A-2 Attire

All exhibitors are required to wear appropriate boots in all classes as well as long sleeve shirts, pants, and hats. A hat must be on exhibitor's head when he or she enters the arena. **ASTM-SEI Equestrian approved helmets are required for the speed and game events and are optional for all other events.**

Clothing and personal attire must be clean, workmanlike, and neat.

All classes will be shown in Western Attire unless otherwise noted. Long pants, long sleeved collared shirt, boots, or hard soled shoes. Western hats, or helmets are required in western style classes. Show management/judges may make exceptions on long sleeves/coats due to weather conditions. English classes attire will be the attire of the style of English ridden. Saddle Seat suits, derby and jog boots are the customary attire for riding Saddle Type horses in a Cut-back English saddle. Dark colored hunt coats, breeches and tall boots with a helmet are customary in Hunt seat style riding with a forward seat saddle.

In all classes exhibitors and judges must bear in mind that all times exhibitors are being judged on ability rather than personal attire. However, judges must penalize contestants who do not conform to tack and attire rules.

A-3 Western Tack

Silver or fancy equipment shall not count over clean, working equipment. Ropes are only to be carried in Ranch Classes. A western/stock saddle must have a horn, high cantle, and skirts, and should be in good working condition. Leg wraps, splint boots, bell boots are prohibited in all classes except Ranch, Reining and speed events. Breast collars are allowed in all classes.

A-4 Western Bits

A curb bit has a solid or broken mouthpiece, has shanks, and works with leverage. A curb strap or curb chain must be utilized with a leverage bit. Shanks may be a maximum of 8 ½" and be loose or fixed.

Mouthpiece bars must be round, oval or egg shaped, smooth unwrapped metal of 5/16ths to 3/4 inches in diameter when measured 1" from the cheek shanks. Nothing may protrude below the mouthpiece, or upward open prongs above on a solid mouthpiece. The mouthpiece may be 2 or 3 pieces, or solid and straight or ported with a maximum of 3.5". The mouthpiece may be a three-piece connected by a ring no larger than 1 1/4" or a flat minimum ½" top to bottom piece, that is no longer than 2". Must lie flat in the horse's mouth.

A curb strap is mandatory with a curb bit, and must be ½" of flat leather, chain, or nylon. A chain curb strap can be a wide flat chain, double welded chain, or double link chain that lies flat against the jaw. Curb chains cannot be tied to the bit by string or cord. Must be connected by a ½" wide leather or nylon strap.

A curb bit is to be ridden with one hand on the reins and is required for horses 6 and older.

Snaffle bits are permissible for junior horses that are 5 years and under. A snaffle is a direct pull bit and has no leverage. Mouthpiece bars must be round, oval or egg shaped, smooth and unwrapped metal of 3/8" to ¾" in diameter measured 1" from the cheeks. The snaffle rings can be the conventional O ring, Egg Butt, D-Ring with the ring no larger than 4" in diameter. The circumference of the ring must be free of rein, curb strap or headstall attachments which would provide leverage. Mouth pieces must be round, oval, egg shaped, smooth and unwrapped metal. The mouthpiece may be two or three pieces. A three piece, connecting ring of 1 ¼" or less in diameter, or a ¾" top to bottom flat piece no longer than 2". A leather or nylon strap may be used on the snaffle to keep the bit from sliding through the mouth. This strap must be attached to the rings below the reins. Snaffles must be ridden with two hands on the reins.

A bosal may be used on young horses 5 and younger. The bosal must be made with a rawhide core, and braided leather or rawhide. No larger than ¾" in diameter. Ridden with two hands with a traditional mecate. This description does NOT include "mechanical Hackamores"

Junior horses refer to horses that are 5 years of age or less. They may be ridden in snaffles or bosals with two hands, or in a curb bit with one hand on the reins. Senior horses are horses that are 6 years and older. They must be ridden in a curb bit and with one hand.

Romal reins are a closed rein that has an extension or attachment that is round or braided. This extension will be carried in the free hand with at least 16" between the rein hand and the free hand holding the Romal. When using Romal reins, the rider's hand shall be around the reins with the wrists kept straight and relaxed, the thumb on top and the fingers closed lightly around the reins. When using the roman, no fingers between the reins are allowed. Commonly used on saddle type horses ridden western.

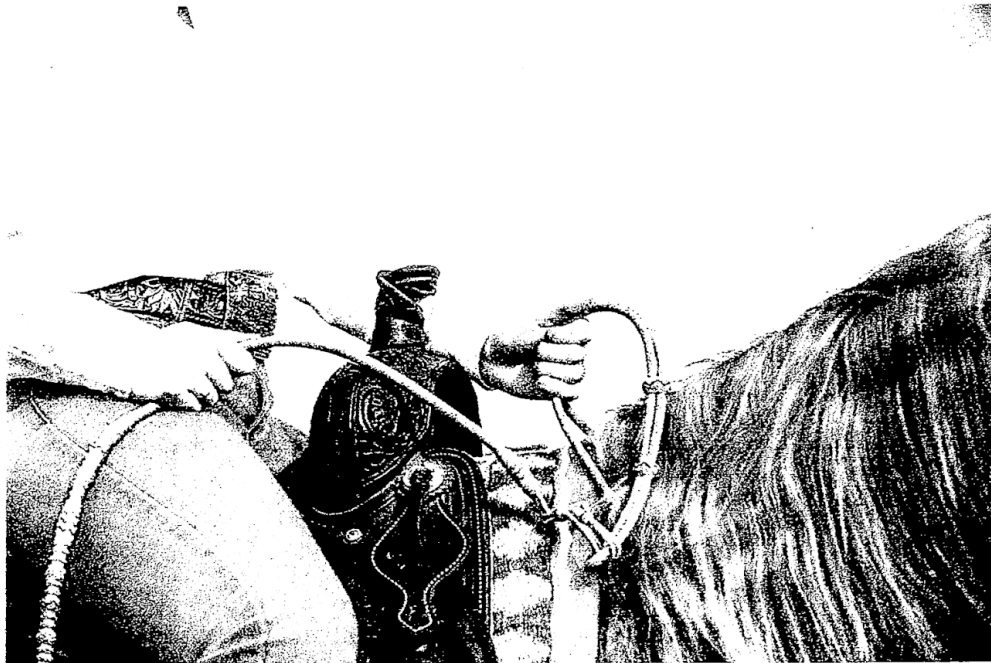

Acceptable use of Romal Reins

Acceptable Snaffle Bit Rein Use



Not Acceptable

Snaffle Bit Rein Use



Not Acceptable



WESTERN BITS

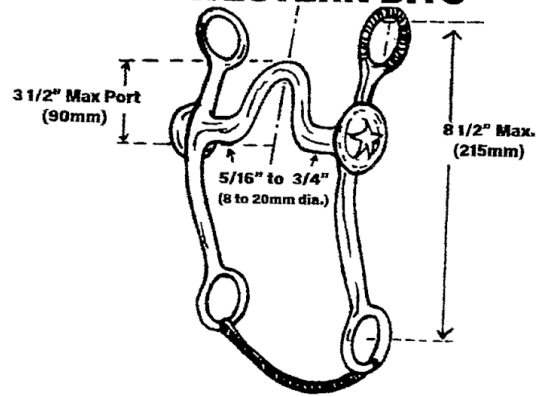

LEGAL BIT

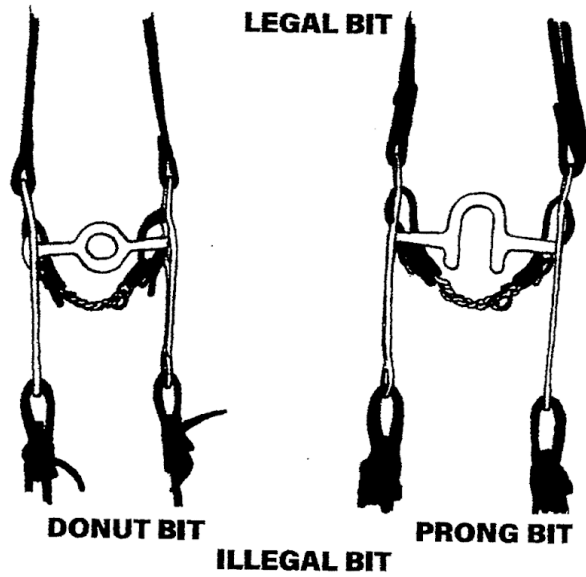

Acceptable chin straps.

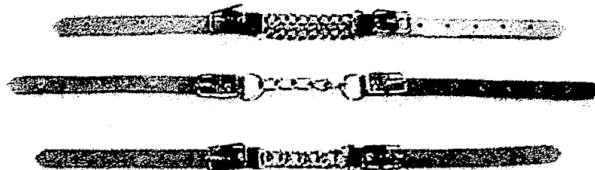

A-5 Speed Events Bit/Tack

Mechanical hackamores, gag bits, along with normal use bits are acceptable to use in speed events. The judge does have the right to have equipment deemed inhumane to be removed. Tie downs, leg wraps, boots are also acceptable. No whipping or spurring in front of the girth allowed. Western saddles must be used. **NO TYING OF RIDER TO SADDLE IN ANY WAY ALLOWED!**

Optional Equipment:

Protective boots, leg wraps, and bandages are allowed in Reining, Ranch Riding and Speed Events Only. Tie downs and martingales may be used in Speed Events Only. No metal or wire may be used for any tie downs or nose bands.

Spurs are optional but must not be worn in Showmanship. Spurs in Showmanship will be a disqualification.

A-6 English Bits & Tack:

Regulation smooth snaffles, pelhams, Kimberwick and full bridles with a cavesson noseband are recommended. Smooth mouthpieces are preferred in all snaffle bits, whether used alone or in a combination. Nothing may protrude below the mouthpiece. Solid and broken mouthpieces must be between 3/8" and 3/4" in diameter, measured 1" from the cheek, and have a port measuring no higher than 1 1/2". Bars may be inlaid, synthetic wrapped but must be smooth. On broken mouthpieces a connecting ring of 1 1/4" or less, or a flat piece 3/4" wide no longer than 2" laying flat in the mouth. Snaffle bit rings may be no larger than 4" in diameter. Any bit having a fixed rein requires use of a curb chain. Saddle types may show in the traditional double bit bridle. Curb chain must lie flat and not be twisted. Mouthpieces must be smooth, round, oval, or egg shaped, slow twist, corkscrew, single twisted wire, double twisted wire, and straight bar or solid allowed. White saddle pads that accommodate numbers are recommended for the hunt seat style of riding.

Saddles must be black or brown of traditional hunting or forward seat type, knee rolls are optional for Hunt Seat showing. Saddle type showing will use a cut-back or flat seat style saddle with larger flaps.

Optional English equipment: unrowelled spurs (no longer than 1 inch), crops or bats, gloves, braiding of mane or tail for Hunt Seat, or braided with ribbons for saddle seat style.

ACCEPTABLE ENGLISH BITS FOR ALL AGES

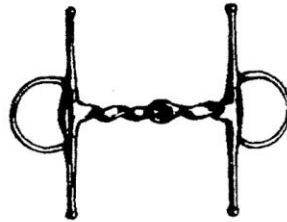

SLOW TWIST

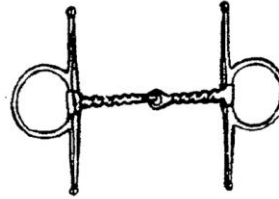

CORKSCREW

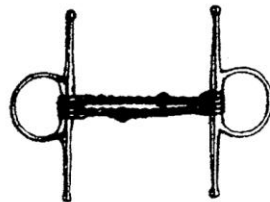

**DOUBLE TWISTED
WIRE**

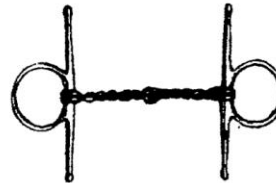

**SINGLE TWISTED
WIRE**

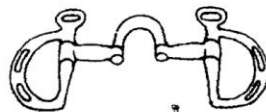

CORRECTION BIT



**SNAFFLE BIT WITH
CONNECTING FLAT BAR**

UNACCEPTABLE ENGLISH BITS

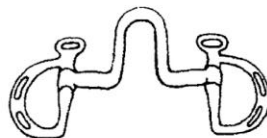

EXCESSIVE PORT

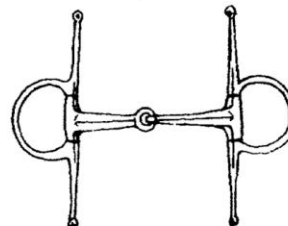

TRIANGULAR MOUTH

Showmanship attire includes a long sleeve shirt or jacket, long pants, and boots. A hat or helmet are required. Horse to be shown in breed standard equipment. Halter to be leather, nylon or rope depending on the style of the breed represented or the exhibitor. A lead shank may be leather with or without a chain. The chain may be under the jaw or over the nose. NEVER in the horse's mouth. Horses shown in Saddle Type style may use a halter or a bridle to show.

Class Guidelines

B-1 Showmanship

Showmanship is designed to evaluate the exhibitor's ability to execute, in concert with a well-groomed and conditioned horse, a set of maneuvers prescribed by the judge with precision and smoothness while exhibiting poise and confidence, and maintaining a balanced, functional, and fundamentally correct body position. It is mandatory that the judge post the initial pattern to be worked at least one hour prior to the commencement of the class; however, if the judge requires additional work of exhibitors for consideration of final placing, an additional pattern may be posted. Pattern(s) should be designed to test the showman's ability to effectively present a horse to the judge. All ties will be broken at the judge's discretion.

Class Procedures

All exhibitors may enter the ring and then work individually or each exhibitor may be worked from the gate individually. When exhibitors are working individually from the gate, a working order is required. The following maneuvers are considered acceptable: lead the horse at a walk, jog, trot, or extended trot, or back in a straight or curved line, or a combination of straight and curved lines; stop; and turn 90 (1/4), 180 (1/2), 270 (3/4), 360 (full turn) degrees or any combination or multiple of these turns. The pull turn is an unacceptable maneuver. The judge must have exhibitors set the horse up for inspection sometime during the class.

Exhibitors are to be scored from 0 to infinity, with 70 denoting an average performance. Patterns will be divided into 6 to 10 maneuvers, as specified by the judge, and each maneuver will be scored from plus 3 to minus 3 with 1/2-point increments acceptable that will be added or subtracted from 70. Maneuver scores should be determined independent of penalties and should reflect equal consideration of both

performance of the exhibitor's pattern and the horsemanship form and effectiveness of the exhibitor to result in the following scores: -3 extremely poor, -2 very poor, -1 poor, 0 average or correct, +1 good, +2 very good, +3 excellent. Exhibitor's overall horsemanship form and effectiveness should also be scored from 0 to 5 with 0 to 2 average, 3 good, 4 very good, 5 excellent.

Overall Presentation of Exhibitor and Horse.

The exhibitor's overall poise, confidence, appearance and position throughout the class, and the physical appearance of the horse will be evaluated. Presentation and Position of Exhibitor. Appropriate western attire must be worn; clothes and person are to be neat and clean.

Exhibitors should be poised, confident, courteous, and genuinely sportsmanlike at all times, quickly recognizing and correcting faults in the positioning of the horse. The exhibitor should continue showing the horse until the class has been placed or they have been excused, unless otherwise instructed by the judge. The exhibitor should appear business-like, stand and move in a straight, natural, and upright manner, and avoid excessive, unnatural, or animated body positions.

The exhibitor must lead on the horse's left side holding the lead shank in the right hand near the halter with the tail of the lead loosely coiled in the left hand. The exhibitor's hand shall not be on the chain portion of the lead. The excess lead should never be tightly coiled, rolled, or folded. When leading, the exhibitor should be positioned between the eye and the mid-point of the horse's neck, referred to as the leading position.

Both arms should be bent at the elbow with the elbows held close to the exhibitor's side and the forearms held in a natural position. Height of the arms may vary depending on the size of the horse and exhibitor, but the arms should never be held straight out with the elbows locked.

The position of the exhibitor when executing a turn to the right is the same as the leading position except that the exhibitor should turn and face toward the horse's head and have the horse move away from them to the right.

When executing a back, the exhibitor should turn from the leading position to face toward the rear of the horse with the right hand extended in front of the exhibitor's chest still maintaining a slight bend in the elbow and walk forward. The ideal position is for the exhibitor's left shoulder to be in alignment with the horse's left front leg. When setting the horse up for inspection, the exhibitor should stand angled toward the horse in a position between the horse's eye and muzzle and should never leave the head of

the horse. The exhibitor is required to use the Quarter Method when presenting the horse. The exhibitor should maintain a position that is safe for themselves and the judge. The position of the exhibitor should not obstruct the judge's view of the horse and should allow the exhibitor to maintain awareness of the judge's position at all times. The exhibitor should not crowd other exhibitors when setting up side-by-side or head-to-tail. When moving around the horse, the exhibitor should change sides in front of the horse with minimal steps and should assume the same position on the right side of the horse that they had on the left side. Leading, backing, turning, and initiating the set-up should be performed from the left side of the horse. At no time should the exhibitor ever stand directly in front of the horse. The exhibitor should not touch the horse with their hands or feet, or visibly cue the horse by pointing their feet at the horse during the set-up

Presentation of Horse.

The horse's body condition and overall fitness should be assessed. The hair coat should be clean, well-brushed and in good condition. The mane, tail, forelock may be braided or banded for English or western, or as the breed type represented. The length of mane and tail may vary, as long as they are neat, clean, and free of tangles. The mane should be even in length or may be roached, but the forelock and tuft over the withers must be left. The bridle path, eyebrows, and long hair on the head and legs may be clipped, except where government regulations or breed standards prohibit. Hooves should be properly trimmed and if shod, the shoes should fit correctly and clinches should be neat. Hooves must be clean and may be painted black or with hoof dressings or shown naturally. The tack should fit properly and be neat, clean and in good repair.

Pattern Performance

The exhibitor should perform the work accurately, precisely, smoothly, and with a reasonable amount of speed. Increasing speed of the work increases the degree of difficulty, however, accuracy and precision should not be sacrificed for speed. The horse should lead, stop, back, turn and set up willingly, briskly, and readily with minimal visible or audible cueing.

The horse should be led directly to and away from the judge in a straight or curved line and track briskly and freely at the prescribed gait as instructed. The horse's head and neck should be straight and in line with the body.

The stop should be straight, prompt, smooth and responsive with the horse's body remaining straight. The horse should back up readily with the head, neck and body aligned in a straight or curved line as instructed. On turns of greater than 90 degrees, the ideal turn consists of the horse pivoting on the right hind leg while stepping across and in front of the right front leg with the left front leg. An exhibitor should not be penalized if their horse performs a pivot on the left hind leg, but an exhibitor whose horse performs the pivot correctly should receive more credit.

The horse should be set up quickly with the feet squarely underneath the body. The exhibitor does not have to reset a horse that stops square.

A pull turn to the left is an unacceptable maneuver

Penalties

Maneuver evaluations and penalty applications are to be determined independently. The following penalties will be applied for each occurrence and will be deducted from the final score:

Three (3) points

- Break of gait at the walk or trot up to 2 strides

- Over or under turning up to 1/8 of a turn

- Ticking or hitting cone

- Sliding a pivot foot

- Lifting a pivot foot during a pivot and replacing it in the same place

- Lifting a foot in a set-up and replacing it in the same place after presentation

Five (5) points

- Not performing the specific gait or not stopping within 10 feet (3 meters) of designated location

- Break of gait at walk or trot for more than 2 strides

- Splitting the cone (cone between the horse and exhibitor)

- Horse stepping out of or moving the hind end significantly during a pivot or turn

- Horse stepping out of set-up after presentation

- Horse resting a foot or hipshot in a set-up

Over or under turning 1/8 to 1/4 turn

Ten (10) points

Exhibitor is not in the required position during inspection

Exhibitor touching the horse or kicking or pointing their feet during the set-up

Standing directly in front of the horse

Loss of lead shank, holding chain or two hands on shank

Blatant disobedience including biting, kicking, rearing, or pawing; horse continually circling exhibitor.

Horse stepping out of or moving the hind end significantly during a pivot or turn more than one time

Disqualifications (should not be placed) including:

Loss of control of horse that endangers exhibitor, other horses, or judge

Horse becomes separated from exhibitor

Failure to display correct number

Willful abuse

Excessive schooling or training; use of artificial aids

Illegal equipment

0 score:

Off pattern, including knocking over or wrong side of cone or marker; never performing designated gait; over or under turning more than 1/4 turn.

B-2 Horsemanship

Western horsemanship is designed to evaluate the rider's ability to execute, in concert with their horse, a set of maneuvers prescribed by the judge with precision and smoothness while exhibiting poise and

confidence and maintaining a balanced, functionally, and fundamentally correct body position. The ideal horsemanship pattern is extremely precise with the rider and horse working in complete unison, executing each maneuver with subtle aids and cues. The horse's head and neck should be carried in a natural position for the breed standard. The head should not be carried behind the vertical, giving the appearance of intimidation, or be excessively nosed out, giving a resistant appearance.

Pattern

It is mandatory that the judge post the pattern to be worked at least one hour prior to the commencement of the class. All patterns (except walk-trot) must include a walk, jog, lope, and a back. Pattern(s) should be designed to test the horseman's ability. All ties will be broken at the judge's discretion.

Class Procedures

All exhibitors must enter the ring and then work individually, or each exhibitor may be worked from the gate individually. The whole class, or just the finalists, must work at all three gaits at least one direction of the arena. The following maneuvers are acceptable in a pattern: walk, jog, extended jog, lope or extended lope in a straight line, curved line, serpentine, circle, figure 8 or combination of these gaits and maneuvers; stop; back in a straight or curved line; turn or pivot, including spins and rollbacks on the haunches and/or on the forehand; side pass, two-track or leg-yield; flying or simple change of lead; counter-canter; or any other maneuver; or ride without stirrups. A back should be asked for sometime during the class. Judges must not ask exhibitors to mount or dismount.

Scoring

Exhibitors are to be scored from 0 to infinity, with 70 denoting an average performance. Patterns will be divided into 6 to 10 maneuvers, as specified by the judge, and each maneuver will be scored from plus 3 to minus 3 with 1/2-point increments acceptable that will be added or subtracted from 70. Maneuver scores should be determined independent of penalties and should reflect equal consideration of both performance of the exhibitor's pattern and the horsemanship form and effectiveness of the exhibitor to result in the following scores: -3 extremely poor, -2 very poor, -1 poor, 0 average or correct, +1 good, +2 very good, +3 excellent. Exhibitors' overall horsemanship form and effectiveness should also be scored from 0 to 5 with 0 to 2 average, 3 good, 4 very good, 5 excellent. Exhibitors should also be judged on the rail, and their pattern score and/or ranking may be adjusted as appropriate

The exhibitor's overall poise, confidence, appearance, and position throughout the class as well as the physical appearance of the horse will be evaluated. The exhibitor should appear natural in the seat and ride with a balanced, functional, and correct position regardless of the maneuver or gait being performed. During the rail work and pattern, the exhibitor should have a strong, secure, and proper position. Exhibitors should sit and maintain an upright position with the upper body at all gaits. The rider should sit in the center of the saddle and the horse's back with the legs hanging to form a straight line from the ear, through the center of the shoulder and hip, touching the back of the heel or through the ankle. The heels should be lower than the toes, with a slight bend in the knee and the lower leg should be directly under the knee. The rider's back should be flat, relaxed, and supple. An overly stiff and/or overly arched lower back will be penalized. The shoulders should be back, level, and square. The rider's base of support should maintain secure contact with the saddle from the seat to the inner thigh. Light contact should be maintained with the saddle and horse from the knee to mid-calf. The knee should point forward and remain closed with no space between the exhibitor's knee and the saddle. The exhibitor will be penalized for positioning the legs excessively behind or forward of the vertical position. Regardless of the type of stirrup, the feet may be placed with the ball of the foot in the center of the stirrup. The rider's toes should be pointing straight ahead or slightly turned out with the ankles straight or slightly broken in. Riding with toes only in the stirrup and riding without contact with the bottom of the stirrup will be penalized. The exhibitor should appear natural in the seat and ride with a balanced, functional, and correct position regardless of the maneuver or gait being performed. During the rail work and pattern, the exhibitor should have a strong, secure, and proper position. Exhibitors should sit and maintain an upright position with the upper body at all gaits. Those exhibitors that can maintain the proper position throughout all maneuvers should receive more credit. When riding without stirrups, the exhibitor should maintain the same position as previously described. Both hands and arms should be held in a relaxed, easy manner, with the upper arm in a straight line with the body. The arm holding the reins should be bent at the elbow forming a line from the elbow to the horse's mouth. The free hand and arm may be carried bent at the elbow in a similar position as the hand holding the reins or straight down at the rider's side. Excessive pumping of the free arm as well as excessive stiffness will be penalized. The rider's wrist is to be kept straight and relaxed, with the hand held at about 30 to 45 degrees inside the vertical. The rein hand should be carried immediately above or slightly in front of the saddle horn. The reins should be adjusted so that the rider has light contact with the horse's mouth, and

at no time shall reins require more than a slight hand movement to control the horse. Excessively tight or loose reins will be penalized.

The rider's head should be held with the chin level and the eyes forward and may be directed slightly toward the direction of travel. Excessive turning of the head to the inside of the circle, or down at the horse's head or shoulder will be penalized.

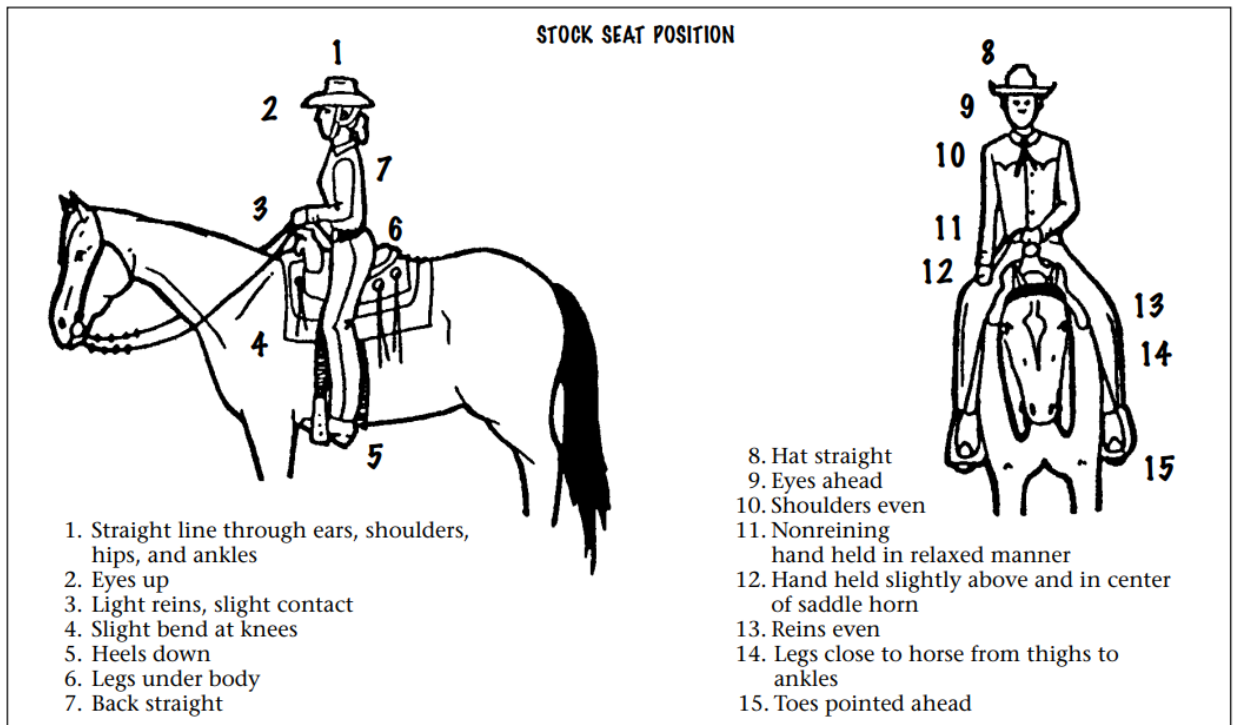

Pattern Performance

The exhibitor should perform the work accurately, precisely, smoothly, and with a reasonable amount of promptness. Increasing speed of the maneuvers performed increases the degree of difficulty; however, accuracy and precision should not be sacrificed for speed. Exhibitors that perform the pattern sluggishly and allow their horse to move without adequate impulsion, collection or cadence will be penalized.

The horse should perform all maneuvers in the pattern willingly, briskly, and readily with minimal visible or audible cueing.

The horse should track straight, freely and at the proper cadence for the prescribed gait. Transitions should be smooth and prompt in the pattern and on the rail and should be performed when called for

on the rail. The horse's head and neck should be straight and in line with their body while performing straight lines and slightly arched to the inside on curved lines or circles. Circles should be round and performed at the appropriate speed, size and location as requested in the pattern. The counter-canter should be performed smoothly with no change in cadence or stride unless specified in the pattern.

The stop should be straight, square, prompt, smooth and responsive with the horse maintaining a straight body position throughout the maneuver. The back should be smooth and responsive.

Turns should be smooth and continuous. When performing a turn on the haunches, the horse should pivot on the inside hind leg and step across with the front legs. A rollback is a stop and 180 degrees turn over the hocks with no hesitation. Backing during turns will be penalized.

The horse should step across with the front and hind legs when performing the side pass, leg-yield, and two-track. The side pass should be performed with the horse keeping the body straight while moving directly lateral in the specified direction. When performing a leg-yield, the horse should move forward and lateral in a diagonal direction with the horse's body arced opposite to the direction that the horse is moving. In the two-track, the horse should move forward and lateral in a diagonal direction with the horse's body held straight or arched in the direction the horse is moving.

A simple or flying change of lead should be executed precisely in the specified number of strides and/or at the designated location. A simple change of lead is performed by breaking to a walk or trot for one to three strides. Flying changes should be simultaneous front and rear. All changes should be smooth and timely. When a lead change is a required maneuver, it may be designated as a simple change or the exhibitor has the option to perform either a simple or flying lead change.

Penalties

Maneuver evaluations and penalty applications are to be determined independently. The following penalties will be applied for each occurrence and will be deducted from the final score:

Three (3) points

Break of gait at the walk or jog up to 2 strides

Over or under turn from 1/8 to 1/4 turn

Tick or hit of cone

Five (5) points

Not performing the specific gait or not stopping within 10 feet (3 meters) of designated location

Incorrect lead or break of gait at the lope (except when correcting an incorrect lead)

Break of gait at walk or jog for more than 2 strides

Loss of stirrup

Bottom of boot not touching pad of stirrup at all gaits including backup

Head carried too low and/or clearly behind the vertical while the horse is in motion, showing the appearance of intimidation

Obviously looking down to check leads

Ten (10) points

Loss of rein

Use of either hand to instill fear or praise while on pattern or during rail work

Holding saddle with either hand

Cueing with the end of the romal

Blatant disobedience including kicking, pawing, bucking, and rearing

Spurring in front of the cinch

Disqualifications (should not be placed) including:

Failure to display correct number

Abuse of horse or schooling

Fall by horse or exhibitor

Illegal equipment or illegal use of 2 hands on reins when in a curb bit

Use of prohibited equipment

OFF PATTERN (op) will not place above a rider that stays on pattern: Off pattern, including: knocking over or wrong side of cone or marker; never performing designated gait or lead; over or under turning more than 1/4 turn.

B-3 Hunt Seat Equitation

The purpose is to evaluate the ability of the hunter rider to perform various maneuvers on his/her horse which provides a base for natural progression to over fence classes. The communication between horse and rider through subtle cues and aids should not be obvious. Equitation is judged on the rider and his/her effect on the horse. Hunt seat equitation on the flat provides a base for a natural progression to over fence classes.

Pattern

It is mandatory that the judge post the pattern at least one hour prior to commencement of the class. All patterns must include a walk, trot, canter and back. Horses' gaits are to be ridden with the same cadence and speed as you would find in the rail phase. All ties will be broken at the discretion of the judge. Judges should not ask exhibitors to mount or dismount.

Hands should be over and in front of horse's withers, knuckles 30 degrees inside the vertical, hands slightly apart and making a straight line from horse's mouth to rider's elbow. The method of holding reins is optional, and bight of reins may fall on either side. The eyes should be up and shoulders back. Toes should be at an angle best suited to rider's conformation, heels down, calf of leg in contact with horse. Iron should be on the ball of the foot. Appropriate English attire must be worn. Clothes and person are to be neat and clean.

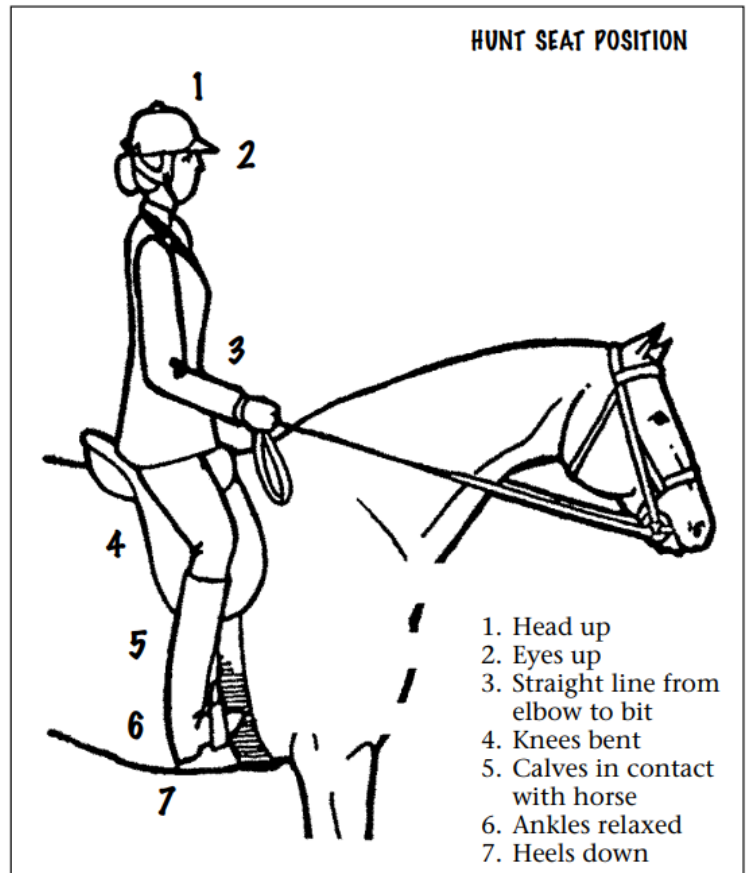

Class Procedure

Exhibitors may be worked individually from the gate or they may all enter at once. The entire class, or only the finalists, must work at all three gaits at least one direction of the arena. Rail work can be used to break ties and possibly adjust placings.

A turn on the forehand to the right is accomplished by moving haunches to the left.

A forehand turn to the left is accomplished by moving haunches to the right.

If riders are asked to drop their irons, they can leave them down or cross them over the withers.

When performing a leg-yield, the horse should move forward and lateral in a diagonal direction with the horse's body straight with a slight flexion of the head in the opposite direction of lateral movement.

When a horse yields to the right, the head is slightly (just to see the eye of the horse) to the left. A horse yielding to the left, the head is slightly flexed to the right.

THE WALK: Should be a four-beat gait with the rider in a vertical position with a following hand.

THE POSTING TROT: Figure 8 at trot, demonstrating change of diagonals. At left diagonal, rider should be sitting the saddle when left front leg is on the ground; at right diagonal, rider should be sitting the saddle when right front leg is on the ground; when circling clockwise at a trot, rider should be on left diagonal; when circling counterclockwise, rider should be on right diagonal. The rider should close his/her hip angle to allow his/her torso to follow the horizontal motion of the horse. The upper body should be inclined about 20 degrees in front of the vertical.

SITTING TROT AND CANTER: At the sitting trot, the upper body is only slightly in front of the vertical. At the canter, the body should be positioned slightly more in front of the vertical. As the stride is shortened, the body should be in a slightly more erect position.

TWO-POINT POSITION: The pelvis should be forward, but relaxed, lifting the rider's weight off the horse's back and transferring the weight through the rider's legs. In this position the two points of contact between horse and rider are the rider's legs. Hands should be forward, up the neck, not resting on the neck.

HAND GALLOP: A three-beat, lengthened canter ridden in two point position. The legs are on the horse's sides while the seat is held out of the saddle. When at the hand gallop, the rider's angulation will

vary somewhat as the horse's stride is shortened and lengthened. A good standard at a normal hand gallop should be about 30 degrees in front of the vertical.

Scoring

Exhibitors are to be scored from 0 to infinity, with 70 denoting an average performance. Patterns will be divided into 6 to 10 maneuvers, as specified by the judge, and each maneuver will be scored from plus 3 to minus 3 with 1/2-point increments acceptable that will be added or subtracted from 70. Maneuver scores should be determined independent of penalties and should reflect equal consideration of both performance of the exhibitor's pattern and the horsemanship form and effectiveness of the exhibitor to result in the following scores: -3 extremely poor, -2 very poor, -1 poor, 0 average or correct, +1 good, +2 very good, +3 excellent. Exhibitors' overall horsemanship form and effectiveness should also be scored from 0 to 5 with 0 to 2 average, 3 good, 4 very good, 5 excellent. Exhibitors should also be judged on the rail, and their pattern score and/or ranking may be adjusted as appropriate.

Penalties. Maneuver evaluations and penalty applications are to be determined independently. The following penalties will be applied for each occurrence and will be deducted from the final score:

Three (3) points

- Break of gait at the walk or trot up to 2 strides
- Over or under turn from 1/8 to 1/4 turn
- Tick or hit of cone
- Missing a diagonal up to 2 strides in the pattern or on the rail

Five (5) points

- Not performing the specific gait or not stopping within 10 feet (3 meters) of designated location
- Incorrect lead or break of gait at the canter (except when correcting an incorrect lead)
- Complete loss of contact between rider's hand and the horse's mouth
- Break of gait at walk or trot for more than 2 strides
- Loss of iron/irons
- Head carried too low and/or clearly behind the vertical while the horse is in motion, showing the appearance of intimidation

Obviously looking down to check leads or diagonals

Missing a diagonal for more than 2 strides in the pattern or on the rail

Ten (10) points

Loss of rein

Use of either hand to instill fear or praise while on pattern or during rail work

Holding saddle with either hand

Spurring or use of the of crop in front of girth

Blatant disobedience including kicking, pawing, bucking, and rearing

Disqualifications (should not be placed)

Failure by exhibitor to wear correct number in visible manner

Willful abuse of horse or schooling

Fall by horse or exhibitor

Illegal use of hands-on reins

Use of prohibited equipment

Off Pattern (op) Off pattern, including: knocking over or wrong side of cone or marker; never performing designated gait, lead, or diagonal; over or under turning more than 1/4 turn will earn a score and may place, but may NOT place over a qualified rider completing the pattern.

B-4 Saddle Seat Equitation

Tack & Attire

Same as for Saddle Seat Pleasure. Clean, workmanlike and neat. Informal attire consists of conservative-colored jackets with matching jodhpurs and derby (helmets are acceptable) or soft hat. Gloves optional. Formal attire consists of dark colored riding habit and accessories or dark tuxedo type jacket and jodhpurs to match with derby or top hat. (Helmets are acceptable) Gloves are acceptable. Tuxedos are usually reserved for evening wear.

Spurs of the unrowelled type that are blunt and round. A slightly flexible whip up to seventy (72) inches in length, including lash is optional.

Hands/Reins

Hands should be held in an easy position, neither perpendicular nor horizontal to the saddle and should show sympathy, adaptability, and control. The height of the hands is held above the withers is in direct proportion to the horse's head. Both hands must be used on the reins.

Basic Position of Rider

By sitting in the middle of the saddle with a slight bend at the knees, but without use of irons, while in this position adjust the leathers and irons to fit. Irons should be placed under the ball of the foot. Foot position should be natural, neither extremely toed in or out.

Pattern

Traditionally Saddle Type Horses will do the Rail Work first, ending with a pattern. Horses will enter the arena tracking counterclockwise. The reverse can be accomplished by turning to or away from the rail Patterns may include a walk, trot on directed diagonals, and canter. Pattern should be designed for saddle type horses with forward motion. The pattern should contain a stop and back and a change of direction.

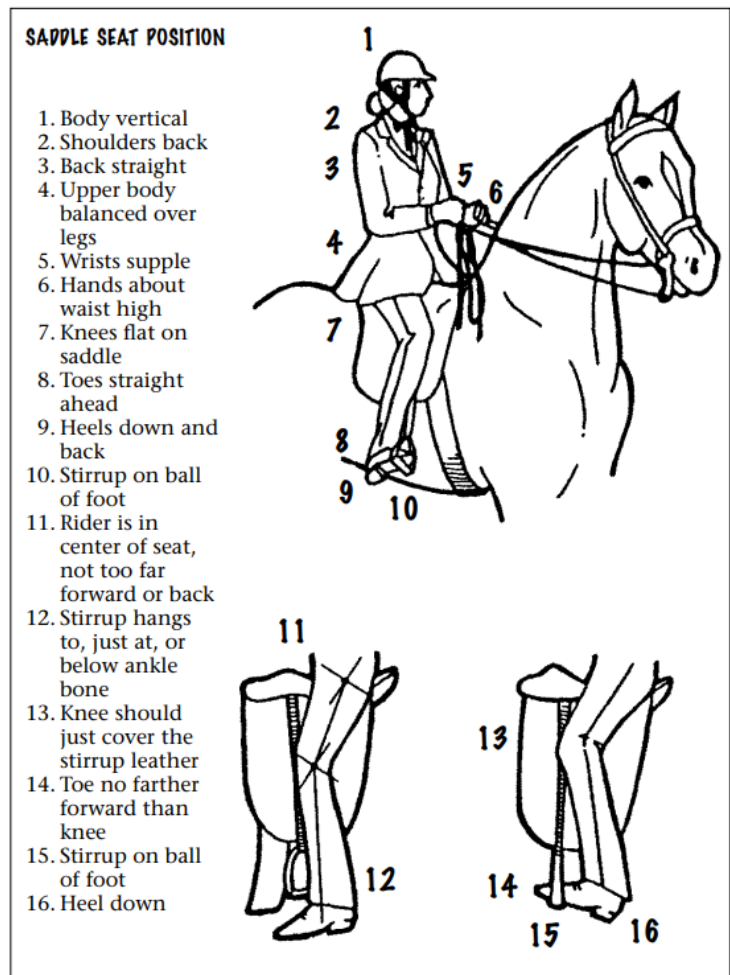

Scoring

Exhibitors are to be scored from 0 to infinity, with 70 denoting an average performance. Patterns will be divided into 6 to 10 maneuvers, as specified by the judge, and each maneuver will be scored from plus 3

to minus 3 with 1/2-point increments acceptable that will be added or subtracted from 70. Maneuver scores should be determined independent of penalties and should reflect equal consideration of both performance of the exhibitor's pattern and the horsemanship form and effectiveness of the exhibitor to result in the following scores: -3 extremely poor, -2 very poor, -1 poor, 0 average or correct, +1 good, +2 very good, +3 excellent. Exhibitors' overall horsemanship form and effectiveness should also be scored from 0 to 5 with 0 to 2 average, 3 good, 4 very good, 5 excellent. Exhibitors should also be judged on the rail, and their pattern score and/or ranking may be adjusted as appropriate.

Penalties

Maneuver evaluations and penalty applications are to be determined independently. The following penalties will be applied for each occurrence and will be deducted from the final score:

Three (3) points

- Break of gait at the walk or trot up to 2 strides
- Over or under turn from 1/8 to 1/4 turn
- Tick or hit of cone
- Missing a diagonal up to 2 strides in the pattern or on the rail

Five (5) points

- Not performing the specific gait or not stopping within 10 feet (3 meters) of designated location
- Incorrect lead or break of gait at the canter (except when correcting an incorrect lead)
- Complete loss of contact between rider's hand and the horse's mouth
- Break of gait at walk or trot for more than 2 strides
- Loss of iron/s
- Obviously looking down to check leads or diagonals
- Missing a diagonal for more than 2 strides in the pattern or on the rail

Ten (10) points

- Loss of rein
- Use of either hand to instill fear or praise while on pattern or during rail work

Holding saddle with either hand

Spurring or use of the of crop in front of girth

Blatant disobedience including kicking, pawing, bucking, and rearing

Disqualifications (should not be placed)

Failure by exhibitor to wear correct number in visible manner

Willful abuse of horse or schooling

Fall by horse or exhibitor

Illegal use of hands-on reins

Use of prohibited equipment

Off Pattern (OP), including: knocking over or wrong side of cone or marker; never performing designated gait, lead, or diagonal; over or under turning more than $\frac{1}{4}$. OP may place in the class but may NOT place over a rider completing the pattern as written.

B-5 Western Pleasure

A class judged on the rail with the horse exhibiting a walk, jog, and lope in both directions of the arena. The horse must reverse by turning towards the center of the arena. Horses must be backed, either on the rail or when brought to the center of the arena. A good western pleasure horse demonstrates a clean and cadenced 4 beat walk, 2 beat jog with stride to match the conformation of the horse, and a relaxed rhythmic three beat lope. Horses should look through the bridle and have a bright expression. Head and neck carriage should be comfortable for the horse and ruled by the conformation/breed standard of the horse. A judge may ask for the extension of any gait. A Junior horse (5 & under) may be shown one hand in a curb bit, or two handed with a snaffle or bosal. Senior horses (6 & older) must be shown one handed with a curb bit.

B-6 Hunter Under Saddle

The purpose of the hunter under saddle horse is to present a horse with a bright, alert expression, whose gaits show potential of being a working hunter. Gaits must be free-flowing, ground covering and athletic. Hunters under saddle should be suitable for purpose, moving with long, low strides reaching forward with ease and smoothness, be able to lengthen stride and cover ground while exhibiting correct

gaits of proper cadence. Quality of movement and consistency of gaits is a major consideration. Horses should be bright, responsive, and smooth in transition. Judges may ask for extension of any gait.

B-7 Non Stock Type Classes

This class provides the Saddlebred/Arabian types an opportunity to show against their own type. American Saddlebreds, Arabian, Morgans are the typical horses found in the saddle-type division. Other non-stock types will also show in this division. Romal reins are popular for riding saddle types, and it is also acceptable to use split reins held in the traditional Romal hand holds, with the tail held in the free hand.

B-8 Non-Stock Type Western Pleasure

Horses will demonstrate a higher head and neck carriage. Can be shown as a junior horse in a snaffle ridden with two hands, or any age horse can ride one handed in a curb bit. Romal Reins is permissible. To be shown at a flat foot walk, jog or trot and lope, both ways of the arena. When asked to reverse the horse should reverse to the inside of the arena. Will be asked to stop and stand quietly, and to back on request either on the rail or lined up in the middle of the arena.

B-9 Non Stock Type English Pleasure

Entries should give the appearance of being a pleasure to ride. To enter the ring to the right at a trot. Non-stock type entries cannot be pre-loaded. To be shown at a walk, trot and canter, both ways of the ring. Entries are required to walk prior to change of gait. To be judged as pleasure horses, based on manners, conformation, suitability, and functional correctness. Gaits to be smooth, balanced, collected, and consistent with the conformation of the horse.

Walk is ground covering, elastic 4 beat gait. Trot demonstrates a balanced, free moving and elastic 2 beat gait,

Canter is collected, smooth and straight on both leads, with 3 beats.

Saddle type movement shall be rounded and may display higher action, with more knee and hock flexion.

Head and neck will be higher, with the nose perpendicular to the ground and ridden with light contact.

B-10 Ranch Riding Pleasure

The ranch riding pleasure class measures the ability of the horse to be a pleasure to ride and should reflect the versatility, attitude, and movement of a working horse. The horse should be well-broke, relaxed, quiet, soft, and cadenced at all gaits. The movement of the working western rail horse should simulate a horse needing to cover long distances, softly and quietly. The overall manners and responsiveness of the horse and the horse's quality of movement are the primary considerations. Maximum credit should be given to the horse that has a natural flowing stride and consistent, ground covering gaits. Transitions should be performed when requested, with smoothness and responsiveness. The ideal working western rail horse should have a natural head carriage at each gait. The horse should be ridden on a relatively loose rein with light contact and without requiring undue restraint while being responsive to the rider and making timely transitions in a smooth and correct manner. The horse should be soft in the bridle, yield to contact and shall not be shown on a full drape of rein. Riders are encouraged to use adequate space given the extension of gaits required. This class should show the horse's ability to work at a forward, working pace while under control by the rider. The horse shall be balanced and appear willing and a pleasure to ride in a group situation.

Horses are to be reversed to the inside (away from the rail) of the arena. They may be asked to reverse at a walk or jog. They are **NOT** to be asked to reverse at the lope.

Riders will NOT be asked to dismount or mount unless the judge wishes to check equipment.

Faults To Be Scored According to Severity

Excessive speed or excessive slowness at any gait

Being on the wrong lead

Breaking gait, including not walking when called for

Excessive slowness in any gait, loss of forward momentum resulting in an animated and/or artificial gait at the lope

Failure to take the appropriate gait when called for, during transitions, excessive delay will be penalized

Over flexing the neck resulting in the nose behind the vertical or excessive nosing out

Opening or gapping the mouth excessively

Stumbling

Use of spur in front of cinch

Overly canted at the lope, quick choppy strides

Excessive head bobbing, or excessive tail wringing

Credits Given in Ranch Riding Pleasure

Consistent natural ground covering gaits

Smooth upward and downward transitions

Working on a reasonable loose rein

Giving the appearance of being able to do a day's work

Softness in the bridle

Disqualifications:

Grabbing or holding the saddle horn or any other part of the saddle

Illegal use of hands-on reins

Use of prohibited equipment

No horse may cross enter a western pleasure or walk/trot western pleasure and Ranch Riding Pleasure class.

Class Requirements:

All exhibitors will work as a group. Individuals working off the rail will not be penalized and passing is permissible. Horses must work both ways of the ring at the walk, trot, and lope. Horses must work at least one way of the ring at the extended trot and extended lope. At the option of the judge, horses may be asked to extend their stride at the walk. The overall cadence and performance of the gaits should have an emphasis on forward, free-flowing, and ground-covering movement.

At the extended trot and lope, the exhibitor may post or stand in the stirrups. **The rider MAY NOT hold the horn or any other part of the saddle. Will result in disqualification**

Horses are to be reversed to the inside (away from the rail). They may be required to reverse at the walk or trot at the discretion of the judge but shall not be asked to reverse at the lope. Horses are required to back easily and stand quietly. Horses may be brought to the center or backed on the rail.

Hoof polish, banded manes, and tail extensions are prohibited.

Equipment with silver should not count over a good working outfit. Excessive silver on bridles and saddles is discouraged.

It is suggested competitors use a breast collar and a rear cinch.

Use of two hands (except junior horses shown in a snaffle bit/hackamore), more than one finger between split reins or any fingers between romal reins shall be cause for disqualification.

Optional Ranch Equipment:

Rope may be carried, coiled, and tied to the saddle

Hobbles attached to saddle

Tapaderos allowed

Protective boots, leg wraps, and bandages

Neck "" git down" rope with romal reins

B-11 Trail

This class will be judged on the performance of the horse over obstacles, with emphasis on manners, response to the rider and quality of movement. Credit will be given to horses negotiating the obstacles with style and some degree of speed, positive expression, and minimal visible or audible cueing, providing correctness is not sacrificed. Horses should receive credit for showing attentiveness to the obstacles and the capability of picking their own way through the course when obstacles warrant it and willingly responding to the rider's cues on more difficult obstacles. Horses shall be penalized for any unnecessary delay while approaching or negotiating the obstacles. Horses with artificial appearance over obstacles should be penalized. Horses must not be required to work on the rail. The course must be designed, however, to require each horse to show the three gaits (walk, jog, lope) somewhere between obstacles as a part of its work, and quality of movement and cadence should be considered as part of the maneuver score. While on the line of travel between obstacles, the horse shall be balanced, carrying

his head and neck in a relaxed, natural position. The head should not be carried behind the vertical, giving the appearance of intimidation, or be excessively nosed out, giving a resistant appearance

The course to be used must be posted at least one hour before scheduled starting time of the class.

Scoring

Scoring will be on the basis of 0-infinity, with 70 denoting an average performance. Each obstacle will receive an obstacle score that should be added or subtracted from 70 and is subject to a penalty that should be subtracted. Each obstacle will be scored on the following basis, ranging from plus 1 1/2 to minus 1 1/2: -1 1/2 extremely poor, -1 very poor, -1/2 poor, 0 correct, +1/2 good, +1 very good, +1 1/2 excellent. Obstacle scores are to be determined and assessed independently of penalty points.

Penalties

Maneuver evaluations and penalty applications are to be determined independently. The following penalties will be applied to each occurrence and be deducted from the final score:

One-half (1/2) point

Each tick or contact of a log, pole, cone, plant, or any component of an obstacle

One (1) point

Each hit, bite, or stepping on a log, cone, plant, or any component of the obstacle

Incorrect or break of gait at walk or jog for two strides or less

Both front or hind feet in a single-strided slot or space at a walk or jog

Skipping over or failing to step into required spaces

Split pole in lope-over

Incorrect number of strides, if specified

Three (3) points

Incorrect or break of gait at walk or jog for more than two strides

Out of lead or break of gait at lope/canter (except when correcting an incorrect lead)

Knocking down an elevated pole, cone, barrel, plant, obstacle, or severely disturbing an obstacle

Falling or jumping off or out of a bridge or a water box with one foot once the horse has gotten onto or into that obstacle

Stepping outside of the confines of an obstacle with designated boundaries (i.e., back through, 360-degree box, side pass) with one foot once the horse has entered the obstacle.

Missing or evading a pole that is a part of a series of an obstacle with one foot

Five (5) points

Dropping slicker or object required to be carried on course

First or second cumulative refusal, balk, or evading an obstacle by shying or backing

Letting go of gate or dropping rope gate

Use of either hand to instill fear or praise

Falling or jumping off or out of a bridge or a water box with more than one foot once the horse has gotten onto or into that obstacle

Stepping outside of the confines of an obstacle with designated boundaries (i.e., back through, 360-degree box, side pass) with more than one foot once the horse has entered the obstacle.

Missing or evading a pole that is a part of a series of an obstacle with more than one foot

Blatant disobedience (including kicking out, bucking, rearing, striking)

Holding saddle with either hand

Disqualified – 0 score

Use of two hands (except in snaffle bit or hackamore classes designated for two hands) or changing hands on reins; except for junior horses shown with hackamore or snaffle bit, only one hand may be used on the reins, except that it is permissible to change hands to work an obstacle or to straighten reins when stopped.

Performing the obstacle incorrectly or other than in specified order

No attempt to perform an obstacle

Equipment failure that delays completion of pattern

Excessively or repeatedly touching the horse on the neck to lower the head

Entering or exiting an obstacle from the incorrect side or direction

Working obstacle, the incorrect direction; including overturns of more than 1/4 turn

Riding outside designated boundary marker of the arena or course area

Third cumulative refusal, balk, or evading an obstacle by shying or backing

Failure to ever demonstrate correct lead and/or gait as designated

Failure to follow the correct line of travel between obstacles

Excessive schooling, pulling, turning, stepping, or backing anywhere on course

Failure to open and shut gate or failure to complete gate

Faults: scored according to severity which occur on the line of travel between obstacles include:

Head carried too high and consistently while the horse is in motion, or otherwise showing the appearance of intimidation.

Opening mouth excessively

B- 12 In-Hand Trail

Class designed for showing ponies or miniature horses that are NOT RIDDEN in Trail.

Exhibitors may only use the right hand on the lead, where the chain begins if using a chain. Left hand must be used to carry the excess lead loosely looped Unless:

Carrying an object from one part of the arena to another

Dragging an object from one part of the arena to another

Opening or closing a gate (left hand gate only to be used)

Side passing, in this case the entire lead shank can be held in the hand at the horse/pony's head

Exhibitors should be poised, confident, courteous, and sportsmanlike at all times. Any stops should be straight, smooth, and responsive with the pony/horse remaining straight. Backing and turning should be

done from the left side of the horse/pony. The exhibitor should turn and face the horse/pony when backing, without standing directly in front of the horse/pony. Exception, when negotiation of a gate, the exhibitor is not required to face the horse. The horse/pony should back up readily with the head, neck and body aligned in a straight or curved line as instructed.

When executing a turn to the right the exhibitor should face the horse/pony and move the animal away from him/her. On turns of less than 90 degrees it is acceptable to pull the horse/pony towards the handler. Turns to the right, Horse/pony should turn on the inside hind leg stepping the front leg across.

Exhibitors are not allowed to touch the horse/pony except when SIDEPASSING.

Obstacles

Will include a minimum of 6 obstacles, and a maximum of 8.

Walk-Overs (poles) at least 4 poles measuring 18"-20" between poles.

Trot-Overs(poles) at least 4 poles measuring 30"-36"

If raised, the poles are to be a maximum of 6"

Back-Through's or Arounds are to be minimum 28"

Serpentines or Jog Arounds Pylons set minimum 3' apart

Gate approximately 60" tall and 5' opening.

Measurements to be taken from the inside of obstacles.

Scoring In Hand Trail

Scoring for In Hand Trail will be the same as the regular Trail. Please check there for the penalties and scoring procedures.

B-13 Ranch Trail

- A) This class will be judged on the performance of the horse over obstacles with emphasis on manners, response to the rider and quality of movement. Credit will be given to horses negotiating the obstacles with style and some degree of speed, providing correctness is not sacrificed. Horses should receive credit for showing attentiveness to the obstacles and the

capability of picking their own way through the course when obstacles warrant it and willingly responding to the rider's cues on more difficult obstacles.

- B) Show management, when setting courses, should keep in mind that the idea is not to trap a horse, or eliminate it by making an obstacle too difficult. All courses and obstacles are to be constructed with safety in mind so as to eliminate any accidents. When the distances and spaces are measured between all obstacles, the inside base to inside base measurement of each obstacle considering the normal path of the horse, should be the measuring point. Enough space must be provided for the horse to trot [at least 30 feet] and lope [at least 50 feet] for judges to evaluate these gaits.
- C) Horses shall be penalized for any unnecessary delay while approaching or negotiating the obstacles. Horses with artificial appearance over obstacles should be penalized.
- D) Horses must not be required to work on the rail. The course must be designed, however, to require each horse to show the three gaits (walk, trot, and lope) somewhere between obstacles as part of its work, and the quality of movement and cadence should be considered as part of the maneuver score. While on the line of travel between obstacles, the horse shall be balanced, carrying his head and neck in a relaxed, natural position. The head should not be carried behind the vertical, giving the appearance of intimidation, or be excessively nosed out, giving the appearance of resistance. Gaits between obstacles should be at the discretion of the judge.
- E) The course to be used must be posted at least 3 (three) classes prior to the first horse entering the arena.
- F) The judge should walk the course and has the right and duty to alter the course in any manner. The judge may remove or change any obstacle he deems unsafe or non-negotiable. If at any time a trail obstacle is deemed unsafe by the judge, it should be repaired or removed from the course. If it cannot be repaired and horses have completed the course, the score for that obstacle shall be deducted from all previous works for that class.
- G) If disrupted, the course shall be reset. In the case that an obstacle is used in combination, the obstacle cannot be reset until the contestant finishes the entire course.
- H) Scoring will be on the basis of 0-infinity, with 70 denoting an average performance. Each obstacle will receive an obstacle score that should be added or subtracted from 70 and each obstacle is subject to a penalty that should be subtracted.

- I) A minimum 6 obstacles must be used, two of which must be from the mandatory list of obstacles and at least four others elected from the list of optional obstacles.

Mandatory Obstacles

1. The gate – a contestant must open, go through, and then close a gate. Reins may not be switched between hands unless done prior to or immediately after the obstacle. The gate must be open and closed, failure to leave the gate as found will result in disqualification.

Optional Obstacles

1. Mail box – Rider approaches mailbox, opens and then closes the door.
2. Slicker – Rider approaches slicker, removes slicker from holder, wears slicker, and then travels to second holder where he removes the slicker and replaces it on the holder.
3. Water hazard – horse shows willingness to cross small ditch or shallow pond.
4. Bridge – Horse shows willingness to walk across obstacle designed to simulate a bridge.
5. Log drag – rider will be handed or pick up rope and drag log according to posted pattern to show horse's willingness and ability to pull. Once the circle is completed, the rider will drop the rope and continue to the next obstacle.
6. "L" shaped back through- course made of logs or poles laid on the ground. Minimum space between poles to be 28".
7. Ground tie or hobble – horse shall remain in place while its rider dismounts and performs a normal ranch task. Split reins- both reins must touch the ground. If using romal reins, the horse must be hobbled or use a neck rope to ground tie.

8. Side pass – logs or poles used must be a minimum of six feet long. Obstacles may be approached from either end and horses may be required to move both directions. Such information is to be stated in the posted pattern.
9. Obstacle containing four (4) logs – each being 5' (minimum) to 6' long laid in a square and executing a 180 or 360 degree turn and then leave square or lope through the square providing the rails are 6' to 7' in length and no more than 12" high. The pattern must state which is required.
10. Logs – Three logs will be placed on ground that the contestant must cross. Walk over 15" to 24" trot over 2'6" to 3'6" lope over 6' to 7'
11. Obstacles consisting of cones or pylons – Horse is to trot through in either a cloverleaf or serpentine pattern or back through as posted on the pattern. Markers are to be spaced at least 3' apart.
12. Any other safe and negotiable obstacle which could reasonably be expected to be encountered on a trail ride and that meets the approval of the judge may be used.
13. A combination of two or more on any obstacles is acceptable.
14. Stationary roping dummy. This obstacle is used to show the willingness of the horse to have a rope thrown from its back. Exhibitors must carry a rope into the class and as they approach the roping dummy may begin to build a loop. A fast and efficient loop build and put away, after roping shall be rewarded. Only one loop will be allowed. The rider must keep hold of the reins. If the rope is dropped before the stationary roping dummy obstacle, the competitor will be a DQ.

The judge will give credit to the horse that stands quietly while the competitor makes the swing and throws at the steer. Shying from the rope will be penalized as to severity. The rider shall not be penalized for a miss but will be credited for the horse being in correct position, standing quietly, pulling slack, and dallying the rope. **NEW FOR 2026**

Unacceptable Obstacles

1. Tires
2. Animals
3. Hides
4. PVC pipes

5. Jumps
6. Rocking or moving bridges
7. Water box with floating or moving parts
8. Flames, dry ice, fire extinguishers, etc.
9. Logs or poles elevated in a manner that permits them to roll.

Scoring And Penalties

Each obstacle will be scored on the following basis, ranging from plus (+) 1 ½ to minus (-) 1 ½: -1 ½ = extremely poor, -1 = very poor, - ½ = poor, 0 = correct, + 1/2, = good, +1 = very good, and + 1 ½ = excellent

Obstacle scores are to be determined and assessed independently of penalty points. Penalties should be assessed per occurrence as follows:

½ POINT PENALTY

- a) Each tick of log, pole, cone, or obstacle
1 POINT PENALTY
- a) Each hit of or stepping on log, pole, cone, or obstacle
- b) Break gait at walk or trot for two strides or less.
- c) Both front and hind feet in a single-strided slot or space at walk or trot.
- d) Skipping over or failing to step into required space.
- e) Split pole on lope over
- f) Incorrect number of strides, if specified.

3 POINT PENALTY

- a) Incorrect or break of gait at walk or trot for more than two strides.
- b) Out of lead or break of gait at lope.
- c) Knocking down an elevated pole, cone, barrel, plant, obstacle or severely disturbing an obstacle.
- d) Fall or jumping off or out of bridge or water box with one foot once the horse has gotten onto or into that obstacle.
- e) Stepping outside the confines of an obstacle with designated boundaries (i.e.: back through, 360 box, side pass) with one foot once the horse has entered the obstacle.

- f) Missing or evading pole is part of a series of obstacles.

5 POINT PENALTY

- a) First and second cumulative refusal, balk or attempting to evade an obstacle. A refusal to address an obstacle is taking two (2) or more steps backwards.
- b) Letting go of the gate or dropping the rope gate.
- c) Use of the hand to instill fear or praise.
- d) Ground tie – second rein not touching ground.
- e) Stepping outside the confines of, falling, or jumping off or out of an obstacle with designated boundaries with more than one foot once the foot has entered the obstacle; including missing one element of an obstacle on a line of travel with two feet.
- f) Blatant disobedience (kicking out, bucking, rearing, or striking).
- g) Holding or touching the saddle with either hand.
- h) Failure to demonstrate correct gait between obstacles as designated.
- i) No dally on the log drag.

FAULTS – which occur on the line of travel between obstacles, are to be scored according to severity:

- 1) Head carriage too high or too low.
- 2) Over-flexing or straining neck in carriage so the nose is carried behind the vertical.
- 3) Excessive nosing out
- 4) Opening mouth excessively.

DISQUALIFICATIONS

- 1) Use of more than one finger between reins.
- 2) Use of two hands (except for snaffle bit/hackamore/mecate as designated two hand) or changing hands on reins; except for junior horses for shown with snaffle/hackamore/mecate, only one hand may be used on the reins, except when it is permissible to change hand to work an obstacle.
- 3) Willful abuse or any inhumane treatment of a horse.
- 4) Use of romal other than outlined in the rule book.
- 5) Performing the obstacle incorrectly or other than in the specified order or no attempt to perform the obstacle.

- 6) Equipment failures that delay completion of pattern
- 7) Fall to the ground by horse or rider.
- 8) Failure to enter, exit or work obstacles from the correct direction, including more than ¼ turn.
- 9) Dropping objects required to be carried on course or losing your rope before attempting to rope the dummy.
- 10) Failure to follow the correct line of travel between obstacles and/or work obstacles in any manner other than how it is described by the course.
- 11) Riding outside the designated boundary markers.
- 12) Third cumulative refusal, balk, or evading an obstacle by shying or backing.
- 13) The gate must be open and closed, failure to leave the gate as found will result in disqualification.
- 14) Failure to dismount to load and unload at the trailer. Horses must remain saddled as they load and unload from the trailer. A contestant must show that a horse will load and unload quietly, safely, and easily from a normal covered stock trailer or horse trailer with secure footing. Exhibitors must dismount to load and unload failure to do so is a disqualification.
- 15) Letting go of reins when attempting to rope the dummy.

B-14 Ranchmanship

(a) The purpose of this class is to bring forth the versatility in both the ranch horse and exhibitor, in the task of performing 1 of the 4 designated patterns, constructed of both Ranch Trail obstacles and Reining maneuvers. Obstacles and maneuvers are to be judged to the standards written in Ranch Trail, Ranch Riding, and Reining in each part of the patterns that pertains to these classes.

(b) Each horse will work individually performing one of the required four (4) patterns offered in the rulebook that is chosen by the judge. Horses will be scored on a basis of 0-100, with 70 denoting an average performance.

(c) There will be no time-limit.

(d) A simple or flying lead change should be executed precisely in the specified number of strides and/or at the designated location. A simple lead change is performed by breaking to a walk or trot for one to

five strides (before break of gait penalty applies). Flying lead changes should be simultaneous front to rear. All changes should be smooth and timely.

(e) This class will also be judged on the quality of movement. For specifics and details of credits, deductions, and penalties refer to the class in question. The Ranch Riding portion will be scored in $\frac{1}{2}$ point increments from $-1\frac{1}{2}$ to $+1\frac{1}{2}$ on the score sheets on the overall quality of the horses movement. Judge will score on all gaits performed at the end of the pattern on the overall average of each gait. Transitions should be performed where designated, with smoothness and responsiveness. Posting at extended trot is acceptable. Exhibitors may not hold the saddle horn.

(f) Exhibitors will be judged on ability and decision making in the show pen. An exhibitor that puts their horse in the correct positions and making the horse's job easier should receive credit. Exhibitors will also be scored in $\frac{1}{2}$ point increments from $-1\frac{1}{2}$ to $+1\frac{1}{2}$ at the end of the pattern for overall performance. No penalties will be given in the quality of movement section of the scoresheet or the ranch hand section of the scoresheet.

Patterns

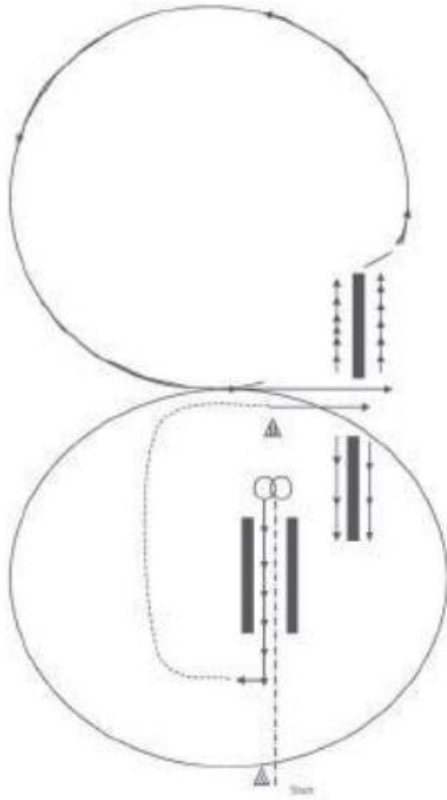

Ranchmanship Pattern #1

1. Extended Trot From Cone through chute; Stop.
2. 1 spin left.
3. 1 spin right.
4. Back through chute 1/4 turn left.
5. Trot to cone.
6. At cone walk to side pass pole.
7. Side pass left.
8. Lope left lead.
9. Change to right lead.
10. Lope right circle; Stop at side pass pole.
11. Side pass right.

RANCHMANSHIP PATTERN #2

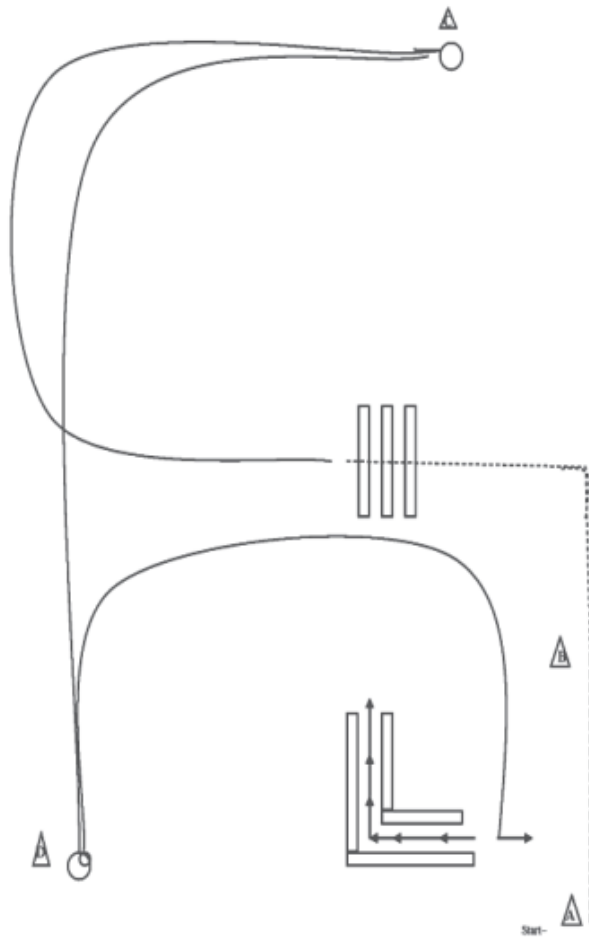

Ranchmanship Pattern #2

1. Walk A-B.
2. At cone trot to and over cross poles.
3. After poles are cleared Right lead lope.
4. At Cone ;Stop.
5. 1½ spin left.
6. Left lead lope to cone; Stop.
7. 1½ spins right.
8. Lope right lead to chute; Stop; 90° turn.
9. Back thru Chute.

RANCHMANSHIP PATTERN #3

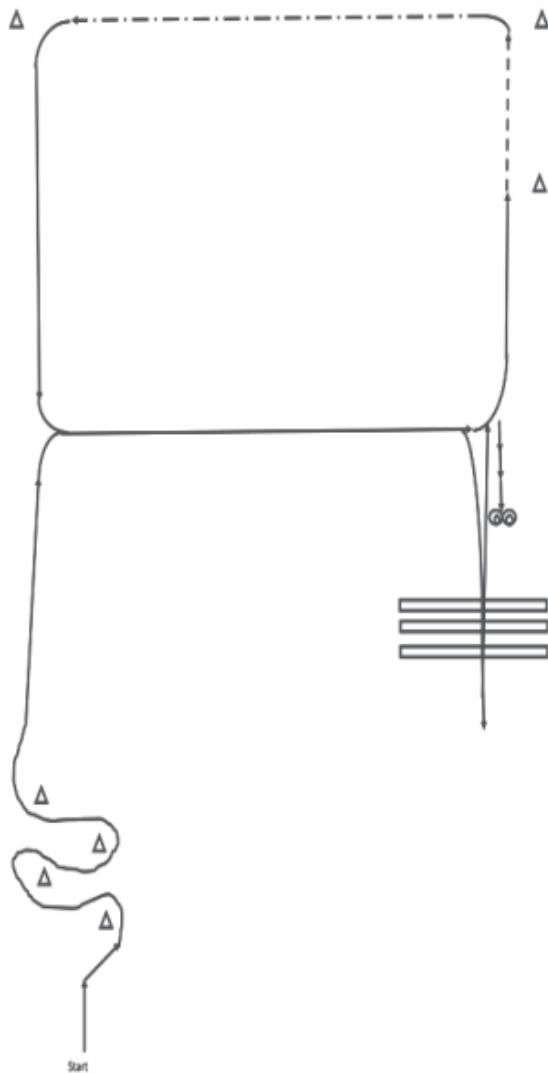

Ranchmanship Pattern #3

1. Trot Serpentine through the cones.
2. Clear last cone; Right Lead Lope.
3. In Center Change to Left Lead.
4. Lope to cone; transition to walk.
5. Walk to next cone.
6. Extended Trot to next cone.
7. Pick up left lead to center.
8. Change to right.
9. Lope through crossover.
10. Stop, Roll Back Left.
11. Lope Back through lope over.
12. Stop Back 8-10 feet.
13. 2 Spins Right.
14. 2 Spins Left.

Additional Ranch Reining Patterns

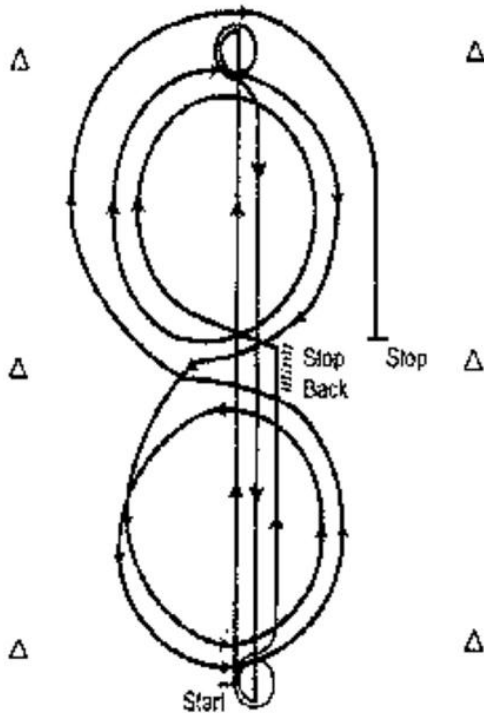

- △ **BEGIN AT END OF THE ARENA**
1. Run to far end of arena past the end marker and stop.
 2. Execute 1 1/2 (one and one-half) spins to the left.
 3. Run to other end of arena past the end marker and stop.
 4. Execute 1 1/2 (one and one-half) spins to the right.
 5. Run past the center marker and stop.
 6. Back 10 to 15 feet in a straight line.
 7. Complete 1/4 (one-quarter) of a turn to the left, hesitate. On right lead complete one small, slow circle and one large, fast circle. Change leads to left.
 8. Complete one small, slow circle and one large, fast circle. Change leads to the right.
 9. Run around the end of arena to the other side, past center marker, at least 20 feet from the fence and stop, hesitate to complete pattern.
 10. Approach judge for inspection and dismissal.
- △ Rider may drop bridle to the designated judge.

B-15 Reining

Reining is a judged event designed to show the athletic ability of a horse in the confines of a show arena. In reining competition, contestants are required to run one of two approved patterns. Each pattern includes small slow circles, large fast circles, rollbacks over the hocks, a series of 360 degree spins done in place, and the exciting sliding stops that are the hallmark of the reining horse.

To rein a horse is not only to guide him, but also to control his every movement. The best reined horse should be willingly guided or controlled with little or no apparent resistance and dictated to completely.

Any movement on his own must be considered a lack of control. One of the two reining patterns to be selected by the judge of the class and used by all contestants in the class. Each contestant will perform the required pattern individually and separately. All horses will be judged immediately upon entering the arena. Any fault incurred prior to the commencement of a pattern will be scored accordingly. All deviations from the exact written pattern must be considered a lack of or temporary loss of control and therefore faulted according to severity of deviation. Credit will be given for smoothness, finesse, attitude, quickness, and authority in performing the various maneuvers while using controlled speed.

Scoring

Scoring will be on the basis of 0 to infinity, with 70 denoting an average performance. Points will be added or subtracted from the maneuvers on the following basis, ranging from plus 1 1/2 to minus 1 1/2: -1 1/2 extremely poor, -1 very poor, -1/2 poor, 0 average, +1/2 good, +1 very good, +1 1/2 excellent. Maneuver scores are to be determined independently of penalty points.

The following will result in no score:

Abuse of an animal in the show arena and/or evidence that an act of abuse has occurred prior to or during the exhibition of a horse in competition; Use of illegal equipment, including wire on bits, bosals or curb chains; Use of illegal bits, bosals or curb chains; when using a snaffle bit, optional curb strap is acceptable; however, curb chains are not acceptable.

Use of tack collars, tie downs, or nose bands

Use of whips or bats

Use of any attachment which alters the movement of or circulation to the tail

Disrespect or misconduct by the exhibitor

Closed reins are not allowed except as standard romal reins and mecates on bosals in classes where the use of two hands is allowed

Excess rein may be straightened anytime during the pattern, provided the rider's free hand remains behind the rein hand

Any attempt to alter tension or length of the reins from bridle to the rein hand is to be considered use of two hands; a penalty score of zero will be applied. In addition, should the judge determine the free hand is being used to instill fear or praise, a penalty five will be applied, and a reduction in the maneuver score.

The following will result in a score of 0:

Use of more than index or first finger between reins

Use of two hands with a curb bit

Failure to complete pattern as written:

Performing the maneuvers other than in specified order or exceeding greater than one quarter of the circle out of order

The inclusion of maneuvers not specified, including, but not limited to:

Backing more than two (2) strides

Turning more than ninety (90) degrees

On run in patterns, once beginning a lope, a complete stop prior to reaching the first marker. (Exception: a complete stop in the 1st quarter (1/4) of a circle after a lope departure is considered an inclusion of maneuver; a two (2) point break of gait penalty will apply.)

Equipment failure that delays completion of pattern; including dropping a rein that contacts the ground while horse is in motion

Balking or refusal of command where performance is delayed

Running away or failing to guide where it becomes impossible to discern whether the entry is on pattern

Jogging in excess of one-half circle or one-half the length of the arena

Overspins of more than 1/4 turn

Fall to the ground by horse or rider

When going to and coming out of a rollback in a pattern requiring a run-around, a rollback that crosses the center line.

The following will result in a reduction of five points:

Spurring in front of cinch

Use of either hand to instill fear or praise

Holding saddle with either hand

Blatant disobediences including kicking, biting, bucking, rearing, and striking

Horse dropping to its knees or hocks.

The following will result in a reduction of two points:

Break of gait

Freeze up in spins or rollbacks

On walk-in patterns, loping prior to reaching the center of the arena and/or failure to stop or walk before executing a lope departure

On run-in patterns, failure to be in a lope prior to the first marker or break of gait prior to the first marker

If a horse does not completely pass the specified marker before initiating a stop position.

Starting or performing circles or eights out of lead will be judged as follows:

Each time a horse is out of lead, a judge is required to penalize by one point. The penalty for being out of lead is cumulative and the judge will deduct one penalty point for each one quarter

(1/4) of the circumference of a circle or any part thereof that a horse is out of lead. A judge is required to penalize a horse 1/2 point for a delayed change of lead by one stride where the lead change is required by the pattern description.

Deduct 1/2 point for starting circle at a jog or exiting rollbacks at a jog up to two strides. Jogging beyond two strides, but less than 1/2 circle or 1/2 the length of the arena, deduct two points.

Deduct 1/2 point for over or under spinning up to 1/8 of a turn; deduct one point for over or under spinning 1/8 to 1/4 turn. A horse can only be assessed one over or under spin penalty per maneuver.

A 1/2-point penalty deduction will be given for failure to remain a minimum of 20 feet (6 meters) from the side of the arena when approaching a stop and/or rollback.

In patterns requiring a run-around, failure to be on the correct lead when rounding the end of the arena will be penalized as follows:

From the turn to the half-way position at end wall, one (1) point

Beyond the half-way point to the beginning of the run down, two (2) points

In a pattern requiring a run-around, there will be a one half (1/2) point penalty for failure to remain a minimum of 10 feet from either side of the center of the arena; for small arenas it will be at the judge's discretion.

A horse which severely stumbles, significantly detracting from the maneuver shall have the maneuver reduced by one half (1/2) point.

Faults against the horse to be scored accordingly, but not to cause disqualification:

Opening mouth excessively when wearing bit.

Excessive jawing, opening mouth or head raising on stop.

Lack of smooth, straight stop on haunches-bouncing or sideways stop.

Refusing to change leads.

Anticipating signals.

Stumbling.

Backing sideways.

Knocking over markers

Patterns

REINING PATTERN A

Approved only for Level 1 Youth & Amateur, Youth 13 & Under

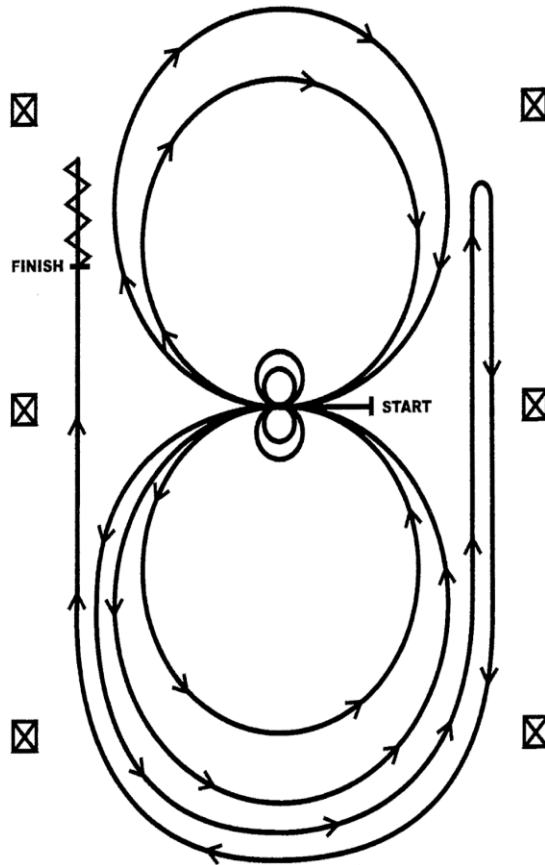

Horses may walk or jog to the center of the arena. Horses must walk or stop prior to starting the pattern. Beginning at the center of the arena facing the left wall or fence.

1. Beginning on the left lead, complete two circles to the left. Stop at the center of the arena. Hesitate.
2. Complete two spins to the left. Hesitate.
3. Beginning on the right lead complete two circles to the right. Stop at the center of the arena. Hesitate.
4. Complete two spins to the right. Hesitate.
5. Beginning on the left lead, go around the end of the arena, run down the right side of the arena past center marker, stop and roll back right.
6. Continue around the end of the arena to run down the left side of the arena past the center marker. Stop. Back up. Hesitate to demonstrate completion of the pattern.

REINING PATTERN B

Approved only for Level 1 Youth & Amateur, Youth 13 & Under

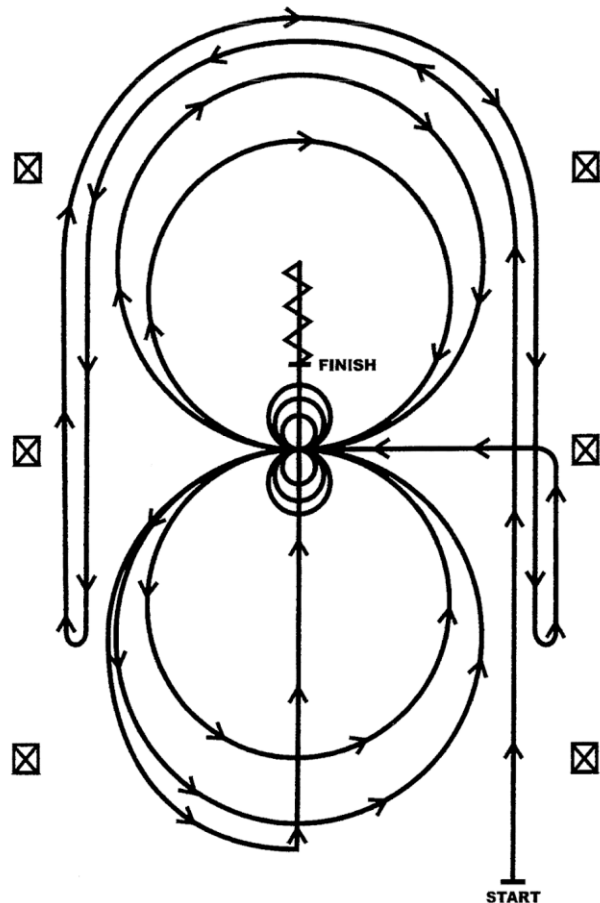

1. Beginning, lope straight up the right side of the arena, circle the top of the arena run straight down the opposite or left side of the arena past the center mark and do a right rollback—no hesitation.
2. Continue straight up the left side of the arena circle back around the top of the arena run straight down the right side of the arena past the center marker and do a left rollback—no hesitation.
3. Continue up the right side of the arena to the center marker, at the center marker the horse should be on the left lead and complete two circles to the left, one large fast and one small slow. Stop at center.
4. Complete three spins to the left. Hesitate.
5. Complete two circles to the right, one large fast and one small slow. Stop at center.
6. Complete three spins to the right. Hesitate.
7. Begin a large circle to the left, do not close the circle. Continue up the center of the arena past the center marker and do a sliding stop.
8. Back up at least ten feet. Hesitate to demonstrate completion of the pattern.

B-16 Gaited Horse Pleasure

This class is for horses that do not have a diagonal gait (trot) and will be judged by the criteria of their breed standard. Horses will show at a walk and optional gait ONLY. **NO CANTER.** To be reversed to the inside of the arena and show both ways of the arena. Will be asked to back. Optional gait will be the gait that is natural to that breed of horse. Any horse displaying a diagonal trot will be disqualified.

B-17 Pony Cart

The equipment required for the pony cart class are a light harness which consists of a bridle with clingers, throatlatch, cavesson, or noseband, overcheck or side check attached to the bit to the saddle, collar or breast collar, reins attached to the bit only passed through the martingale (optional if used) through the saddle terrets. Whip is required to be in the cart or exhibitor's hand. Martingales, check bits, thimbles, and breaching are optional. Appropriate bits, including leverage bits, half check snaffle, Liverpool, and bradoon overcheck may be used. To be hitched to a suitable two- or four-wheel cart with wooden or metal spoked wheels. A basket is mandatory; cart should be suitable to the pony.

Entries should be serviceably sound.

Attire

Drivers should conform to the type (breed) and turnout of the pony but should always be neat and clean. Appropriate attire for gentlemen includes hat, coat or jacket, shirt, pants, and tie. Attire for ladies includes tasteful dresses, tailored suit, skirt, or slacks, with blouse, vest, or jacket. Hats, gloves and or apron/lap robes are optional.

Headers are required and must be 14 or older and must be dressed appropriately.

Entries to give the appearance of being a pleasure to drive. All gaits are to be performed in a smooth, relaxed, balanced manner, consistent with the conformation type of the pony. The walk should be a flat-footed walk, a rhythmical four beat gait. The Pleasure Trot balanced, free moving, relaxed two beat gaits. Working trot has a balanced lengthening of stride with noticeable difference from the Pleasure Trot without excessive speed or loss of form. All entries will be brought to the center and asked to back individually.

Judged on manners, quality, performance, conformation, and suitability. Faults would be stiff choppy gaits, inconsistent rhythm. The tendency to move in a western pleasure type jog should be penalized. Extreme speed should be penalized. To enter the arena counter clockwise at a Pleasure Trot.

B-18 Speed Events

ASTM-SEI Equestrian approved helmets are required for the speed and game events and are optional for all other events.

In speed events, western - type equipment must be used. Mechanical hackamore nosepieces must be covered in leather and cannot have visible or bare metal in contact with the horse's head. The judge or steward may prohibit the use of any bit or equipment they consider inhumane or would tend to give a horse/rider an unfair advantage. Tie-downs, used speed events must be leather, flat nylon or rope a minimum of 3/8 inch in diameter.

Bonnets (tie-down that goes over the poll and/or across the forehead) made of rope, flat nylon webbing or leather only (minimum 3/8-inch diameter) are permitted. The judge has the authority to disqualify/dismiss any rider that the judge feels the equipment being used may be excessively severe.

General Rules for Speed Events

1. ASTM-SEI Equestrian approved helmets are required for the Speed Events
2. In the event of a tie, the exhibitor declared the winner in the run-off must re-run the pattern within two seconds of his/her original time or the run-off must be held again. Penalty time will not apply to the two-second rule but will apply to the final run-off time. Failure to run pattern correctly or any other disqualification shall not apply to the two-second rule but shall apply to the final run-off time (resulting in a no time for the re-run).
3. Failure to run a pattern correctly shall disqualify an exhibitor.
4. Exhibitors must walk into the arena, no running in and out of the gate.
5. An exhibitor crossing the finish line before completing a pattern shall be disqualified.
6. The judge, at their discretion, may disqualify a contestant for excessive use of a bat, crop whip, or rope in front of the cinch.

7. Western type equipment must be used.

8. A rider will be disqualified if the helmet is not on the exhibitor's head for the entire time the exhibitor is in the arena.

9. Under no circumstance is a rider to be secured or tied to a saddle, including rubber banding the feet to the stirrups.

B-19 Barrel Racing

ASTM-SEI Equestrian approved helmets are required for the speed and game events and are optional for all other events.

Exhibitors race against the clock, following a course consisting of three barrels in a triangular “cloverleaf” pattern. Contestants must choose either the right or left barrel, circle it, and go to the next barrel, completing the course after circling the third barrel and running home. Barrel racing is a timed event.

The contestant will walk into the arena before picking up a run. The contestant will run to barrel number 1, pass to the left of it, and complete an approximately 360 degree turn around it; then go to barrel number 2, pass to the right of it, and complete a slightly more than 360 degree turn around it; then go to barrel number 3, pass to the right of it, and do another approximately 360 degree turn around it; then sprint to the finish line, passing between barrel number 1 and 2. This barrel course may also be run to the left. For example, the contestants will start to barrel number 2, turning to left around this barrel, then to barrel number 1, turning to the right, then to barrel number 3, turning again to the right, followed by the final sprint to the finish line.

Penalties

Knocking over a barrel carries a five-second penalty.

Failure to follow the course shall cause disqualification.

A contestant may touch the barrel with his or her hands in barrel racing.

A whip may not exceed two feet in length excluding over and under's which must be attached to the saddle.

B-20 Pole Bending

ASTM-SEI Equestrian approved helmets are required for the speed and game events and are optional for all other events.

This timed event consists of a series of six poles spaced 21 feet apart, which horses and riders weave through at a high rate of speed. Horses run to the far end of the series of poles, turn and weave in and out as they work their way back to the front. Horses then complete a turn around the front pole and maneuver through the series again. At the last pole, they complete that turn and race toward the finish line at full speed. Each contestant will begin from walking into the arena, and time shall begin and end as the horse's nose crosses the line. A clearly visible starting line must be provided. A horse may start either to the right or to the left of the first pole and then run the remainder of the pattern accordingly.

Penalties

Knocking over a pole shall carry a five-second penalty.

Failure to follow the course shall cause disqualification.

Contestants may touch a pole with his or her hand in pole bending.



SHOW: _____
 CLASS: _____
 DATE: _____

AQHA TRAIL

W/O	#	OBSTACLE SCORES												PENALTY TOTAL	SCORE
		-1 1/2 Extremely Poor, -1 Very Poor, -1/2 Poor, 0 Correct, +1/2 Good, +1 Very Good, +1 1/2 Excellent													
Obstacle Description															
Obstacle		1	2	3	4	5	6	7	8	9	10	11	12		
		PENALTY													
		OBS SCORE													
		PENALTY													
		OBS SCORE													
		PENALTY													
		OBS SCORE													
		PENALTY													
		OBS SCORE													
		PENALTY													
		OBS SCORE													
		PENALTY													
		OBS SCORE													
		PENALTY													
		OBS SCORE													
		PENALTY													
		OBS SCORE													

JUDGE'S NAME (PRINTED): _____

JUDGE'S SIGNATURE: _____

TRAIL OBSTACLE SCORES:

+1 1/2 - Excellent, +1 - Very Good, +1/2 - Good, 0 - Correct, -1/2 - Poor, -1 - Very Poor, -1 1/2 - Extremely Poor

PENALTY 1/2:

Each tick of log, pole, cone or obstacles

PENALTY 1:

Hit, bite or step on; Incorrect gait at walk or jog 2 strides or less; Both feet in space; Skip space; Split pole, failure to meet the correct strides on trot over & lope over log, incorrect number of strides, if specified

PENALTY 3:

Break gait at walk or jog over 2 strides; Out of lead or break of gait at lope; Knockdown: Step out or jump off with 1 foot; Missing or evading a pole that is part of an obstacle with one foot

PENALTY 5:

Drop object; 1st refusal or evade; 2nd refusal; Loss of control at gate: Use of either hand to instill fear or praise; Step out or jump off obstacle with more than 1 foot; Blatant disobedience; Failure to complete obstacle: Holding saddle

PENALTY SCORE 0:

Failure to follow the correct line of travel within or between obstacles; Use of 2 hands; Use of romal other than outlined; Performing obstacles incorrectly or other than specified order; No attempt to perform obstacle; Equipment failure; Excessively or repeatedly touching the horse on the neck to lower the head; Fall to ground; Failure to enter, exit or work obstacle from correct side or direction, including overturns of more than 1/4 turn; Failure to work an obstacle other than how it is described; Outside boundary marker of arena or course area; 3rd refusal; Failure to demonstrate correct lead or gait; On line of demonstrate correct lead or gait; Excessive schooling anywhere on course; Failure to open and shut gate or to complete gate



PATTERN CLASS SCORE SHEET

Show: _____
 Date: _____
 Judge: _____
 Signature: _____

Circle Division: Youth Walk/Trot, Youth Level 1, Youth 13 <, Youth 14-18, Youth Walk/Trot, Amateur Level 1, Amateur Select, Amateur, Amateurship, Horsemanship, Equitation

WO Entry #	Maneuver Description	Each rider is scored between 0-infinity points and automatically begins the run with a score of 70 points -3 Extremely Poor, -2 Very Poor, -1 Poor, 0 Correct, +1 Good, +2 Very Good, +3 Excellent										F&E	Total Penalty	Score	Comments	
		1	2	3	4	5	6	7	8	9	10					
	Penalty															
	Maneuver															
	Penalty															
	Maneuver															
	Penalty															
	Maneuver															
	Penalty															
	Maneuver															
	Penalty															
	Maneuver															
	Penalty															
	Maneuver															