

MU Guide

Settling Basins and Terraces for Cattle Manure

Charles D. Fulhage and Donald L. Pfost, Agricultural Engineering Extension
John W. Feistner, Natural Resources Conservation Service

Fast-moving liquids pick up and transport solids, which settle out of the flow when velocity is reduced. Often, settling basins are designed to limit flow velocities to 1.5 feet per second, or less. Settling may remove 35 percent to 60 percent of the solids from a dilute liquid slurry, with as little as 10 minutes detention time (30 to 60 minutes detention time is common). Settled solids, submerged in water, typically are about 15 percent dry matter. After dewatering, the solids are usually 15 percent to 25 percent dry matter and can be used as fertilizer or composted. Figure 1 is a schematic of a typical settling basin.

Liquids separated from animal manure must be contained in a lagoon, storage basin or settling basin until they are land-applied to a vegetative filter or soil-plant filter. The liquid should be applied to a vegetative or soil-plant filter large enough to use the nitrogen content.

Settling basins add to the overall cost of a waste management system. They may require two handling systems: one for solids and one for liquids.

Settling basins

Settling basins may be used to reduce the nutrient-loading on a lagoon from a gutter-flushing system but are used more commonly to reduce the nutrient-loading on a vegetative filter strip from lot runoff. Adding a settling basin to remove a portion of the solids can decrease the required lagoon volume for a new facility,

or it can enable you increase the animal units served by an existing lagoon. Settling is a good way to remove undesirable material, such as hay, straw and feathers, from the waste flow to a lagoon. It can reduce odors or prevent a crust or mat from forming on the lagoon surface. You may need a baffle to retain floating solids (such as straw) in a settling basin. By removing the larger solids, you can reduce plugging of liquid-handling equipment, such as pumps and irrigation sprinkler nozzles.

There are two types of settling basins, based on the method of removing solids. With one type, the solids are removed mechanically (after the free water has drained away), usually with a front-end or skid-steer loader. The depth of accumulated solids should not exceed 1.5 feet. The other type uses hydraulic (pump) removal of the solids. Typically, pumping is initiated when the basin is half full of solids and the remainder is water. Vigorous agitation is needed to mix the liquid and the solids, preferably by propeller-type agitators or pumps with agitation nozzles.

Settling basins may be either concrete or earthen structures. For concrete basins, a common recommendation is a minimum depth of 2 feet plus the depth required for solids storage. Figure 2 shows a typical concrete settling basin. A simplified version of this type of basin without the screen has been developed by NRCS engineers for dairy operations in southwest

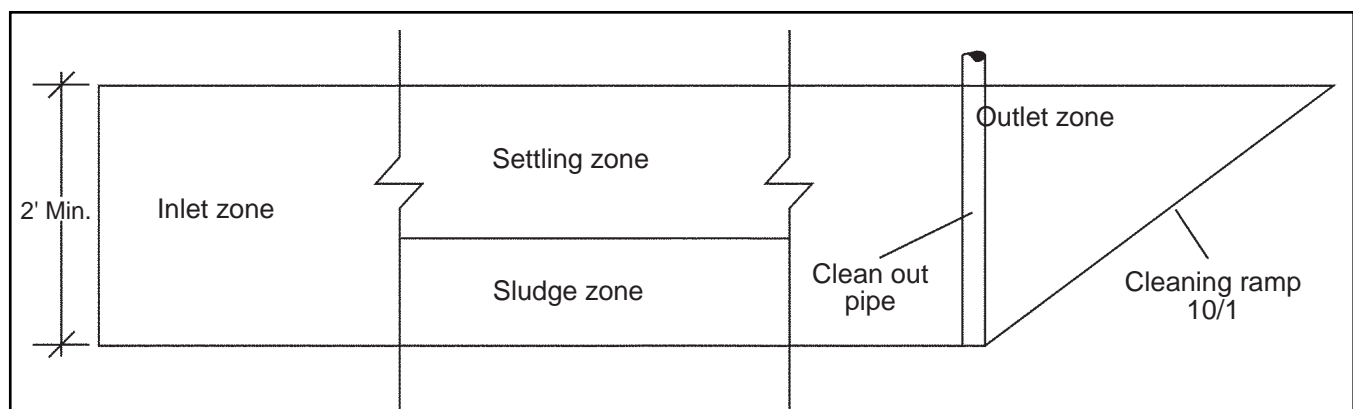

Figure 1. Schematic representation of four-zone settling.

Missouri. Earthen structures may be used for compact basins, settling terraces, settling diversion terraces or settling channels. Figure 3 shows a typical earthen settling basin. Earthen basins to be cleaned with loaders are usually designed to be shallow (not more than 3 feet deep) and to cover a large area. Earthen settling basins should have a concrete entrance ramp and a concrete runway on the bottom to allow entry of equipment for solids removal. Figure 4 shows a duplex concrete settling basin that allows one side to receive effluent while the other side is thoroughly dewatered and the solids removed.

A settling terrace, a settling diversion terrace or a settling channel is a wide, shallow, gently sloping, flat-bottomed waterway in which runoff solids settle because of low velocity. The channel is sometimes grassed to improve settling and reduce erosion. Grass may not survive in the channel and can make cleaning more difficult. Grass should be maintained on the sideslopes, if possible. Solids should be removed annually, or more often if required, to maintain capacity. Berm tops should be at least 2 feet wide to maintain the design height and at least 12 feet wide for vehicle traffic.

In Missouri's humid climate, inadequate drying of the solids and the channel may limit the usefulness of earthen settling terraces and channels.

Design of concrete settling basins

The following example illustrates the design of a concrete settling basin. A worksheet is included.

Example 1

Design a concrete settling basin for a dirt lot, 100 feet by 200 feet, on a 6 percent slope. The solids will be pumped out at 6-month intervals. The basin length is to be four times the basin width. The location is in the northeast corner of Missouri. Design using peak runoff rate for a 1-yr./10-yr. storm from Table 1.

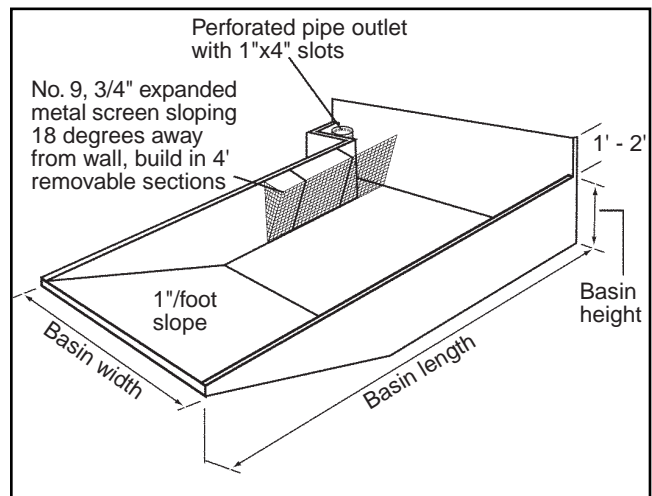

Figure 2. A typical concrete settling basin designed for mechanical removal of solids (from MWPS-18).

1. Open lot area draining into the basin:

Lot length 200 ft x lot width 100 ft = lot area 20,000 ft²

2. Inflow rate into settling basin:

Q = peak runoff rate in ft³/sec/A (Table 1)

L = location factor (Figure 5)

T = topographic factor (Table 2)

Q_T = inflow rate into settling basin, ft³/hr

$Q_T = Q \times L \times T \times \text{ft}^2 \text{ lot area} \times 0.0411 = \text{ft}^3/\text{hr}$

$Q_T = 5.5 \text{ ft}^3/\text{sec}/A (Q) \times 0.96 (L) \times 0.92 (T) \times 20,000 \text{ ft}^2 \times 0.0411 = 3,993 \text{ ft}^3/\text{hr}$

If inflow arrives at settling basin by a sewer pipe, estimate Q_T from the size of the sewer pipe in Table 3.

$Q_T = \text{gpm (Table 3)} \times 8 = \text{ft}^3/\text{hr}$

If inflow arrives at settling basin by other means (i.e., a dairy flush alley discharging into settling basin).

Estimate inflow rate:

$Q_T = \text{estimated gpm} \times 8 = \text{ft}^3/\text{hr}$

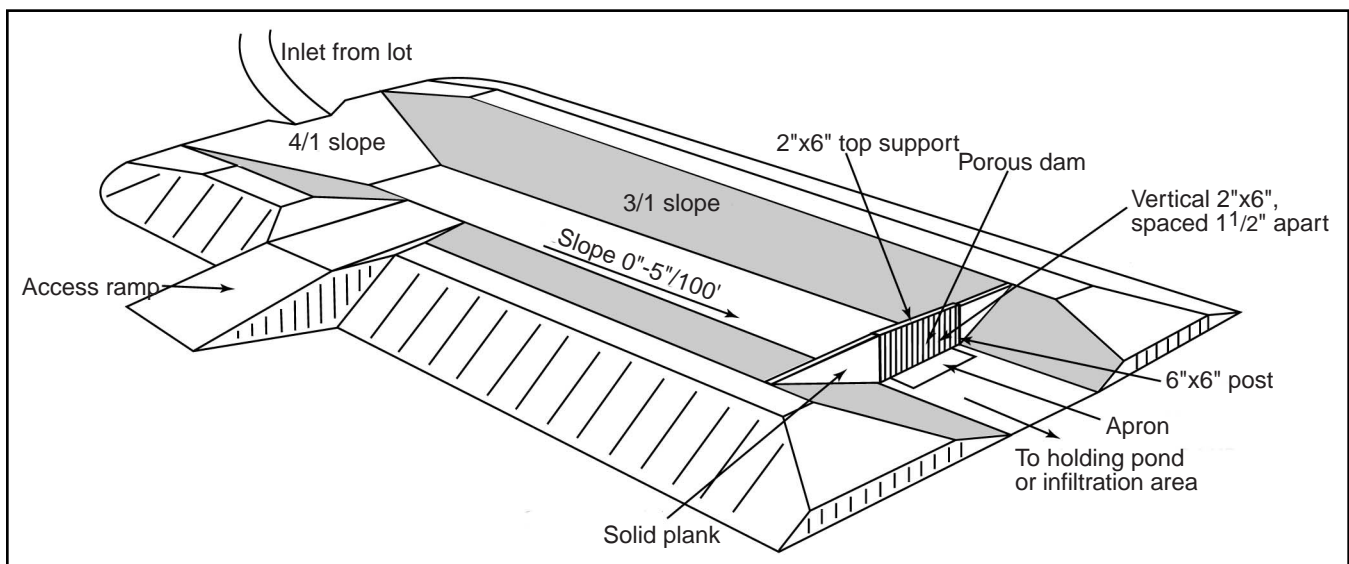
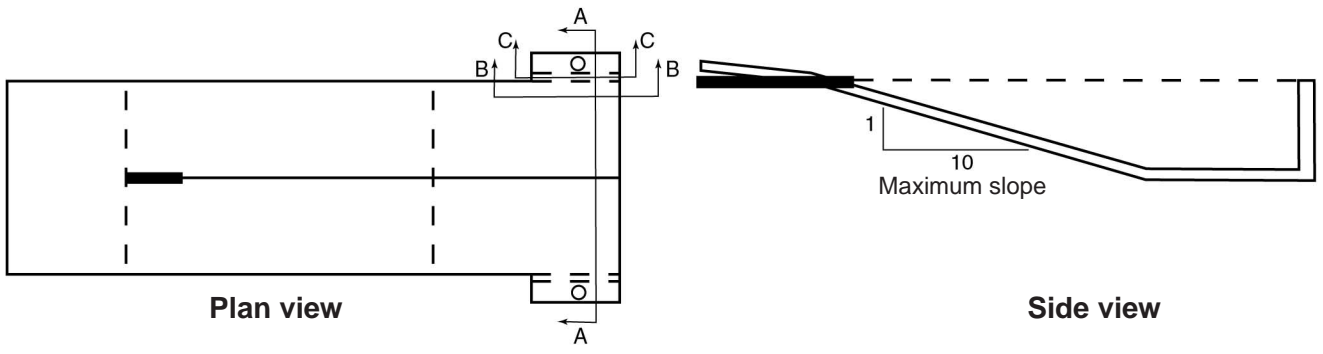
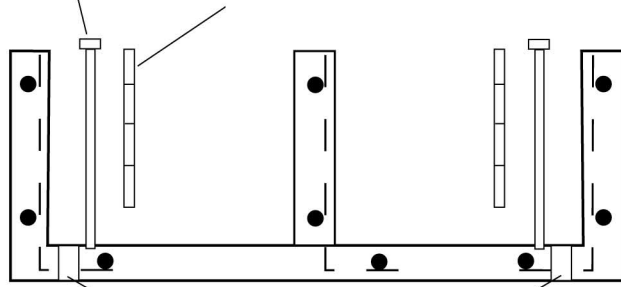

Figure 3. A typical earthen settling basin designed for mechanical removal of solids (from MWPS-18).



Pressure-treated 4"x4"s placed vertically with 3/4" spaces between

Pressure-treated 2"x6"s placed horizontally with no space between and a 6" space at the bottom



Cross section A-A

Note: concrete walls are 6" thick; floors are 4" thick.
Rebar as specified by engineer for as-built height

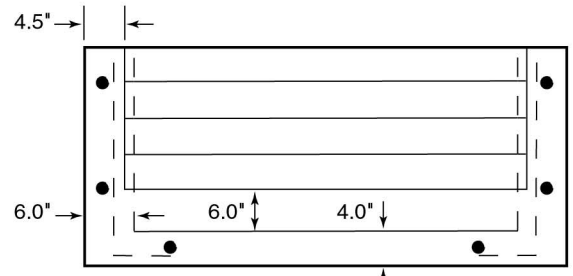

Place a 1.5" x 1.75" groove on each side to place the treated 2"x6" boards in. The groove will start 6" from the bottom

Cross section B-B

Use galvanized lag bolts to fasten the 4"x4" top plate to the vertical 4"x4"s

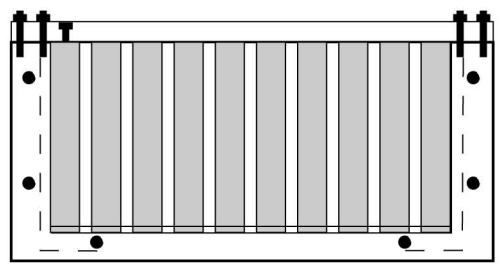

Two 1/2" galvanized anchor bolts placed in concrete to secure the 4"x4" top plate that holds the vertical 4"x4"s in place

Cross section C-C

Figure 4. Duplex concrete settling basin.

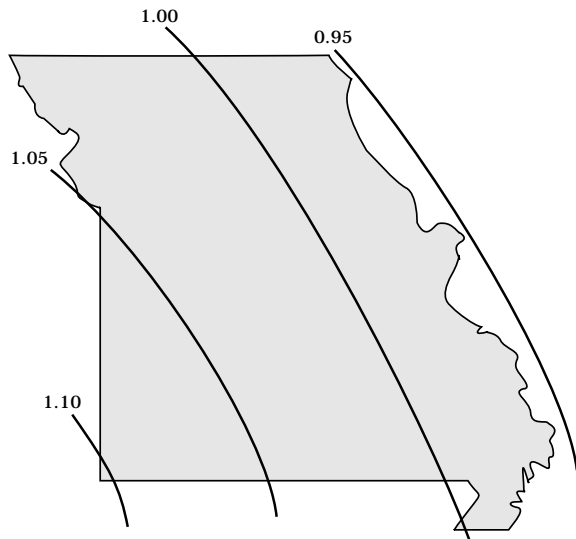

Figure 5. Location factors (L).

3. Surface area (SA) of settling basin:

$$SA \text{ (ft}^2\text{)} = \frac{Q_T \text{ (ft}^3\text{/hr)}}{4 \text{ ft}^3\text{/hr/ft}^2} = \frac{3,993 \text{ ft}^3\text{/hr}}{4 \text{ ft}^3\text{/hr/ft}^2} = 998 \text{ ft}^2$$

4. Basin dimensions. Design basin for length = 3 to 5 times basin width.

$$\text{Basin width} = [SA/R]^{0.5}$$

SA = basin surface area, ft² (from Step 3)

R = length-width ratio = 4

$$\text{width} = [998 \text{ ft}^2 \text{ (SA)} \div 4 \text{ (R)}]^{0.5} = 15.8 \text{ ft}$$

$$\text{length} = 16 \text{ ft (width)} \times 4 \text{ (R)} = 64 \text{ ft}$$

5. Basin overflow.

Provide a rectangular overflow weir at the downstream end of basin. Weir height = 6 inches. Maximum weir length = width of settling basin. Minimum weir length, ft = $Q_T/1,250$. If a riser pipe is used as an overflow device instead of a rectangular weir, riser pipe diameter, inches = $Q_T/274$. Do not use a riser pipe smaller than 6 inches in diameter.

$$\begin{aligned} \text{Minimum rectangular weir length} &= Q_T/1,250 \\ &= 3,993 / 1,250 \\ &= 3.2 \text{ ft} \end{aligned}$$

$$\begin{aligned} \text{Minimum riser pipe diameter} &= Q_T/274 \\ &= 3,993 / 274 \\ &= 14.6 \text{ inches} \end{aligned}$$

6. Basin depth.

Use the following as a guide for volume of solids and calculate depth required for desired storage period.

Dirt lots = 2,800 ft³/acre-yr

Concrete lots and confinement buildings = 0.5 times manure production volume (Table 4).

If solids are to be removed from the basin by pumping, design the basin to hold an equal volume of water above settled solids. Solids must be diluted and agitated for pumping. If solids are to be removed mechanically (i.e., front-end loader), provide concrete entrance to settling basin with a maximum 10:1 slope (20:1 slope

Table 1. Peak rates of runoff to be expected from watersheds in Missouri (Q).

Acres	1 yr/10 (ft ³ /sec/A)	1 yr/25 ^a (ft ³ /sec/A)
0-1	5.5	7.2
1-2	4.6	6.0
2-3	4.2	5.5
3-4	3.0	5.2
4-20 ^b	2.8	5.1

Notes:

a. 1 yr/10 is sufficient in most design situations. However, if a settling terrace is adjacent to a stream, use 1yr/25.

b. For areas greater than 20 acres, refer to MU publication G1518, *Estimating Peak Rates of Runoff from Small Watersheds*, Table 1.

Table 2. Topographic factors for different land slopes.

Average land slope (percent)	Topographic factor (T)
1	0.65
2	0.72
3	0.78
4	0.83
5	0.88
6	0.92
7	0.96
8	1.00
9	1.04
10	1.07
12	1.14
14	1.20

Source: MU publication G1518, *Estimating Peak Rates of Runoff from Small Watersheds*.

Table 3. Diameter, slope and expected flow rates for sewer lines.

Diameter (inches)	Slope (ft/ft)	Expected flow rate (GPM)
4	0.02	115
6	0.013	255
8	0.009	460
10	0.007	750

Table 4. Approximate daily manure production.

Animal	Weight (pounds)	Cu. ft/day (liquid + solid)
Dairy cow, lactating	1,000	1.7
Dairy cow, dry	1,000	1.3
Beef feeders		
High-energy ration	1,100	1.26
High-forage ration	1,100	1.40
Swine, finish	1,000	1.0
Sow + litter	1,000	1.0
Gestation sow	1,000	0.44
Boar	1,000	0.34
Sheep	1,000	0.6
Poultry		
Layers	1,000	1.0
Broilers	1,000	1.5
Horse	1,000	0.8

preferred). Additional dewatering by means of a hardware cloth dam or a perforated riser pipe is desirable for mechanical removal of settled solids.

Indicate desired storage period, days = 182
(Lot acres = 100 feet x 200 feet/43,560 = 0.46 acres)

$$\text{Basin depth (dirt lot)} = \frac{2,800 \times 0.46 \text{ acre lot} \times 182 \text{ days storage} \times 2^*}{365 \text{ days/yr} \times 998 \text{ ft}^2 \text{ surface area (Step 3)}} = 1.3 \text{ ft}$$

*Multiply by 1 for mechanical removal or by 2 for pumping.

Basin depth, BD_C (concrete lot or confinement building)

$$BD_C = \frac{0.5 \times \text{ft}^3/\text{day manure (Table 4)} \times \text{days storage} \times 2^*}{\text{ft}^2 \text{ surface area (Step 3)}}$$

*Multiply by 1 for mechanical removal or by 2 for pumping.

Note: When settling basin discharges into a lagoon, the size of the lagoon may be reduced as follows:

Design volume (w/settling basin) = Design volume (w/o settling basin) x 0.5

Manure storage volume (w/settling basin) = Manure storage volume (w/o settling basin) x 0.5

The minimum design storage period is 90 days when the lagoon design volume is reduced by 50 percent as noted above. Less storage may be used if the lagoon design volume is based on 100 percent loading.

Basin outlets

Various types of basin outlets are used to drain liquids from the full depth of basins and allow the solids to dewater. The porous plank dam (Figure 4, Sec. C-C) ahead of either a perforated or a slotted riser pipe are frequently used outlets. Manure tends to plug even large openings in outlets. Unplugging is required frequently. A hoe may be used to scrape solids off of openings. Also, a slanted expanded metal or quarry screen with 1-inch to 1½-inch openings may be used around the outlet to increase the screening area and reduce clogging.

Porous dams

Porous dams may be made of welded wire fabric, expanded metal mesh or spaced boards. Porous dams may be used to dewater settling basins or to remove large solids that tend to cause excessive clogging of the openings in perforated pipe outlets. Dams constructed with spaced boards usually have ¾-inch spaces between the boards. The boards usually range from 2-by-6s to 2-by-12s. Expanded metal and welded wire fabric have even greater open areas. Due to the large open area in a porous dam, little design is required. As a general rule, the open area in a porous

dam should be twice the area of the perforations in the riser pipe it precedes. As a practical matter, a porous dam 4 feet long or more, should suffice for the common sizes of outlet pipes. In some applications, there is no outlet pipe and the porous dam forms one wall of the settling/storage basin.

Perforated pipe outlets

Material for perforated pipe is usually PVC plastic, galvanized steel or concrete. Perforations can be ⅝-inch to 1-inch diameter holes or 1-inch by 4-inch slots. The outlet is sized to match the anticipated flow rates to ensure adequate detention time. Flow rate is controlled by the amount of open area (slots or holes) in the pipe. Table 5 gives opening requirements for perforated pipes.

Example

Design a basin outlet to allow outflow to equal peak flow rate off the lot in Example 1 when the basin is full. The inflow rate in Example 1 is 3,993 cubic feet per hour and the depth is 1.3 feet.

1. For a perforated pipe riser, determine the required open area per foot of pipe height from Table 5. Outflow = 3,993 ft³/hr = 1.1 ft³/sec. By interpolation in Table 5, we find that with 1.3 feet of head, the

Table 5. Riser pipe outlet design for settling basins.

Open slot area per foot of pipe height, in ² /ft	Head, ft							
	0.5	1.0	1.5	2.0	2.5	3.0	3.5	4.0
	cfs							
4	0.034	0.093	0.169	0.259	0.361	0.473	0.596	0.728
6	0.051	0.139	0.253	0.388	0.541	0.710	0.894	1.091
8	0.068	0.186	0.338	0.518	0.721	0.947	1.192	1.455
10	0.085	0.232	0.422	0.647	0.902	1.183	1.480	1.819
12	0.102	0.279	0.507	0.776	1.082	1.420	1.788	2.183
14	0.119	0.325	0.591	0.906	1.262	1.657	2.086	2.546
16	0.136	0.371	0.675	1.035	1.443	1.894	2.384	2.910
18	0.153	0.418	0.760	1.164	1.623	2.130	2.682	3.274
20	0.170	0.464	0.844	1.294	1.803	2.367	3.890	3.638
22	0.187	0.511	0.929	1.423	1.984	2.604	3.277	4.001
24	0.204	0.557	1.013	1.542	2.164	2.840	3.575	4.365
26	0.221	0.603	1.097	1.682	2.344	3.077	3.873	4.729
28	0.238	0.650	1.182	1.811	2.525	3.314	4.171	5.093
30	0.255	0.696	1.266	1.940	2.705	3.550	4.469	5.456
32	0.272	0.743	1.351	2.070	2.885	3.787	4.767	5.820
34	0.289	0.789	1.435	2.199	3.066	4.024	5.065	6.184
36	0.306	0.836	1.519	2.329	3.246	4.260	5.363	6.548
38	0.323	0.882	1.604	2.458	3.426	4.497	5.661	6.911
40	0.340	0.928	1.688	2.587	3.607	4.734	5.959	7.275

Source: MWPS-18.

Note: Based on: $Q = (C)(A)(2gh)^{0.5}$, where Q = flow rate in cfs; C = slot constant, assumed to be 0.61; A = open slot area in ft²; g = 32.174 ft/sec²; h = head on openings in feet. The pipe height is divided into 0.5-foot increments. The head on all the slots in the first 0.5-foot increment is assumed to be 0.25 foot. The head on subsequent 0.5-foot increments increases at 0.5-foot increments.

required opening area in the riser pipe is 32 square inches per foot of pipe height.

- Size the outlet pipe from the data in Table 3. Outflow in gpm = $1.1 \text{ ft}^3/\text{sec} \times 450 \text{ gpm}/\text{cfs} = 495 \text{ gpm}$. From Table 3, an 8-inch pipe at 0.009 slope will carry 460 gpm and a 10-inch pipe at 0.007 slope will carry 750 gpm. Depending on slope, use an 8-inch or 10-inch pipe (an 8-inch pipe will carry 1.1 cfs at slopes greater than 1 percent, Ref. Fig. 4.5b in MWPS-18).

Check on the time to withdraw the 9,167 cubic feet of runoff from the 25-year, 24-hour storm (Figure 6) at 1.1 cfs.

$$\begin{aligned} \text{Time in hours} &= 9,167 \text{ ft}^3 \div (1.1 \text{ ft}^3/\text{sec} \times 3,600 \text{ sec}/\text{hr}) \\ &= 2.3 \text{ hours at maximum head} \end{aligned}$$

Design of earthen settling basins

To meet approval by the Missouri Department of Natural Resources, earthen basins must be built as follows. Berms shall have maximum slopes of 3:1. If solids are to be removed using mechanical equipment, a concrete pad shall be installed in the bottom of the basin and a concrete access ramp with a maximum slope of 10 percent shall be provided. If the settled solids are to be removed by pumping, the basin must be designed to contain an equal volume of water above the solids to allow for agitation and dilution of the solids. Access points for the mixing equipment must be indicated on the construction drawings.

For more information on the design of earthen storage basins/lagoons, consult your local NRCS engineer or your extension regional agricultural engineering specialist. You may get their names from your local NRCS office or University Extension center. The engineers have a computer program available for design of earthen storage basins.

Design of settling channels

A settling diversion terrace, settling terrace or a settling channel is a wide, shallow, gently sloping, flat-bottomed channel, in which suspended solids contained in runoff water are settled out. A settling channel may be either of earthen or concrete construction. The settling channel may be grassed to improve settling and reduce erosion. Runoff water from the channel is stored in a lagoon or storage pond. Wastes settled from the runoff are allowed to dry before removal with mechanical equipment, typically with a tractor and front-end loader. Usually, solids are removed from the channel once per year or when accumulated solids reduce the settling ability of the channel.

Sideslopes for settling channels usually range from 3:1 to 4:1, depending on soil properties. The bottom slope of the channel should be between 0.1 percent and 0.3 percent to maintain low velocities and rapid settling.

The following example shows how to design a settling terrace or channel. Blanks are provided for your specific design.

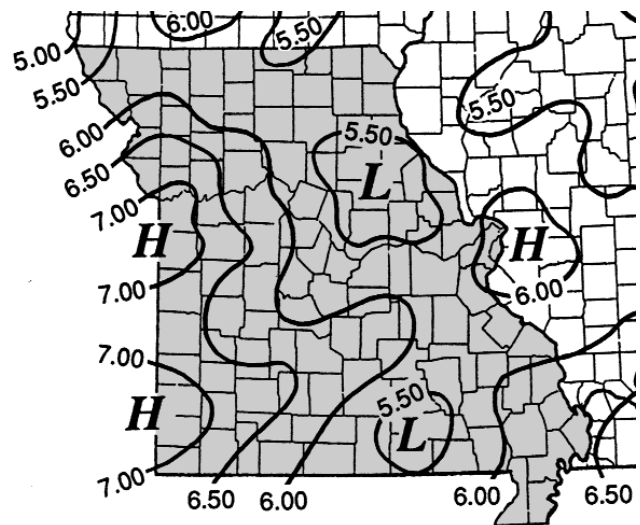

Figure 6. 25-year - 24-hour rainfall.

Table 6. Trapezoidal settling channel design.

Bottom slope (%)	Depth (ft)	Bottom width (ft)						
		10	15	20	25	30	35	
0.1	0.5	fps	0.6	0.7	0.7	0.7	0.7	0.7
		cfs	3.7	5.5	7.4	9.2	11.1	12.9
	1.0	fps	0.9	1.0	1.0	1.0	1.1	1.1
		cfs	12.2	17.9	23.6	29.4	35.2	41.0
	1.5	fps	1.2	1.2	1.3	1.3	1.3	1.4
		cfs	25.1	36.0	47.1	58.4	69.7	81.1
2.0	fps	1.3	1.4	1.5	1.5	1.6	1.6	
	cfs	42.8	60.0	77.7	95.6	113.7	131.9	
0.2	0.5	fps	0.9	0.9	1.0	1.0	1.0	1.0
		cfs	5.2	7.8	10.4	13.0	15.6	18.2
	1.0	fps	1.3	1.4	1.5	1.5	1.5	1.5
		cfs	17.3	25.3	33.4	41.6	49.8	58.0
0.3	0.5	fps	1.1	1.2	1.2	1.2	1.2	1.2
		cfs	6.4	9.6	12.8	15.9	19.1	22.3

Note: These low-slope channels settle solids out of runoff. The lower the water velocity, fps, the higher the settling rate. Construct the channel at least 0.5 foot deeper than the table value to allow for solids storage. Bottom slope as shown, sideslopes = 3:1 and $n = 0.04$.

Table 7. Settling channel volumes (ft^3/ft of channel length).

Channel width (ft)	Channel depth (ft)					
	0.5	1.0	1.5	2.0	3.0	4.0
10	5.75	13.0	21.75	32	57	88
15	8.25	18	29.25	42	72	108
20	10.75	23	36.75	52	87	128
25	13.25	28	44.25	62	102	148
30	15.75	33	51.75	72	117	168
35	18.25	38	59.25	82	132	188
40	20.75	43	66.75	92	147	208
50	25.75	53	81.75	112	177	248
60	30.75	63	96.75	132	207	288

Assumptions: 3:1 sideslopes, vertical ends, bottom nearly flat, volume = $LD(W + 3D)$, use $LD(W + 4D)$ for 4:1 sideslopes.

Example 2

Design a settling terrace (or channel) for the dirt lot 100 feet by 200 feet on a 6 percent slope in Example 1. The location is in the northeast corner of Missouri. Design using peak runoff rate for a 1-yr./10-yr. storm from Table 1. Assume 3:1 sideslopes and a 0.1 percent bottom slope. Design for a maximum velocity of 1 fps and a detention time of one hour.

1. Open lot area draining into the channel:

$$\text{Lot length } 200 \text{ ft} \times \text{lot width } 100 \text{ ft} = \text{lot area } 20,000 \text{ ft}^2 = 0.46 \text{ acre}$$

Your design:

$$\text{Lot length } __ \text{ ft} \times \text{lot width } __ \text{ ft} = \text{lot area } __ \text{ ft}^2 = __ \text{ acre}$$

2. Inflow rate into settling channel:

Q = peak runoff rate in $\text{ft}^3/\text{sec}/\text{A}$ (Table 1)

L = location factor (Figure 5)

Y = topographic factor (Table 2)

Q_T = inflow rate into settling channel, ft^3/hr

$$Q_T = Q \times L \times T \times \text{ft}^2 \text{ lot area} \times 0.0411 = \text{ft}^3/\text{hr}$$

$$Q_T = \frac{5.5 \text{ ft}^3/\text{sec}/\text{A} \times 0.96 (L) \times 0.92 (T) \times 20,000 \text{ ft}^2 \times 0.0411}{0.0411} = 3,993 \text{ ft}^3/\text{hr} = 1.1 \text{ cfs}$$

Your design:

$$Q_T = __ \text{ ft}^3/\text{sec}/\text{A} \times __ (L) \times __ (T) \times __ \text{ ft}^2 \times 0.0411 = __ \text{ ft}^3/\text{hr}$$

$$__ \text{ ft}^3/\text{hr} \div 3,600 \text{ sec/hr} = __ \text{ ft}^3/\text{sec} (\text{cfs})$$

If inflow arrives at settling terrace/channel through a sewer pipe, estimate Q_T from the size of the sewer pipe in Table 3.

$$Q_T = __ \text{ gpm (Table 3)} \times 8 = __ \text{ ft}^3/\text{hr} = __ \text{ ft}^3/\text{sec}$$

If inflow arrives at settling terrace/channel by other means, explain (i.e., a dairy flush alley discharging into terrace/channel basin).

Estimate inflow rate :

$$Q_T = __ \text{ estimated gpm} \times 8 = __ \text{ ft}^3/\text{hr} = __ \text{ ft}^3/\text{sec}$$

3. From Table 6, find the width and depth to limit velocity to 1 fps.

A channel 20 feet wide and 0.5 foot deep on a 0.2 percent

slope will limit velocity to 1.0 fps and will drain better than a flatter slope.

Your width: $__ \text{ ft}$; your depth: $__ \text{ ft}$; your slope: $__ \text{ percent}$

4. Determine the minimum channel volume required for a 1-hour detention time:

Minimum channel volume $\text{ft}^3 = (\text{channel capacity, } 1.1 \text{ cfs}) \times (\text{detention time, } 1 \text{ hr}) \times 3,600 \text{ sec/hr} = 3,960 \text{ ft}^3$

Your design:

$$\text{Channel volume } \text{ft}^3 = (\text{channel capacity } __ \text{ cfs}) \times (\text{detention time } __ \text{ hr}) \times 3,600 \text{ sec/hr} = __ \text{ ft}^3$$

5. Divide the minimum channel volume by the volume/foot of channel length values (in Table 7) to get the minimum channel length based on volume required for detention time:

From Table 7 for the 0.5-foot deep channel, 20 feet wide, as selected in Step 3, volume per foot is 10.75 ft^3 .

Channel volume $3,960 \text{ ft}^3 \div \text{volume per ft } 10.75 \text{ ft}^3 = \text{minimum length of channel } 368 \text{ ft}$

Your design:

$$\text{Channel volume } __ \text{ ft}^3 \div \text{volume per ft } __ \text{ ft}^3 = \text{minimum length of channel } __ \text{ ft}$$

6. Determine the depth of channel required to store the accumulated solids volume assuming once per year solids removal:

Annual solids volume (ft^3) = $2,800 \text{ ft}^3/\text{acre-year} \times 0.46 \text{ acre} = 1,288 \text{ ft}^3$

If a 6-inch depth will contain $3,960 \text{ ft}^3$ in 368 feet of channel, then the required depth for $1,228 \text{ ft}^3$ of solids can be approximated as follows:

$$6 \text{ inches} \times 1,228 \div 3,960 = 1.95 \text{ inches}$$

Your design:

$$\text{Liquid depth } __ \text{ inches} \times \text{solids volume } __ \text{ ft}^3 \div \text{liquid volume } \text{ft}^3 = \text{solids depth } __ \text{ inches}$$

Determine total channel depth for both solids and liquid:

$$6 \text{ inches for liquid} + 1.95 \text{ inches for solids} = 7.95 \text{ inches total depth}$$

Construct channel at least 1 foot deep to allow for freeboard.

Your design:

$$__ \text{ inches for liquid} + __ \text{ inches for solids} = __ \text{ inches total depth}$$

For further information

Schneider, John H., Susan B. Harrison, and Paul B. Freeze. 1993. *No Discharge Gated Pipe Distribution of Feedlot Runoff*. ASAE Paper No. 93-4566. St. Joseph, Mich.

USDA-Natural Resources Conservation Service. 1992. *Agricultural Waste Management Field Handbook*, Part 651. USDA-NRCS, Washington, D.C.

Available from Extension Publications 1-800-292-0969

MU publications

M115 *Missouri Approach to Animal Waste Management Planning and Designing Guidelines*

Midwest Plan Service Publications

MWPS-18 *Livestock Waste Facilities Handbook*



Published with funds provided to the Missouri Department of Natural Resources and the Environmental Protection Agency, Region VII. To learn more about water quality and other natural resource issues, contact the Missouri Department of Natural Resources, P.O. Box 176, Jefferson City, MO 65102. Toll free 1-800-361-4827.

Worksheet for concrete settling basins

1. Open lot area draining into the basin:

Lot length _____ ft × lot width _____ ft = lot area _____ ft²

2. Inflow rate into settling basin:

Q = peak runoff rate in ft³/sec/A (Table 1)

L = location factor (Figure 5)

T = topographic factor (Table 2)

Q_T = inflow rate into settling basin, ft³/hr

Q_T = Q × L × T × ft² lot area × 0.0411 = ft³/hr

Q_T = _____ ft³/sec/A × _____ (L) × _____ (T) × _____ ft² × 0.0411 = _____ ft³/hr

If inflow arrives at settling basin through a sewer pipe, estimate Q_T from the size of the sewer pipe in Table 3.

Q_T = _____ gpm (Table 2) × 8 = _____ ft³/hr

If inflow arrives at settling basin by other means, explain (i.e., a dairy flush alley discharging into settling basin).

Estimate inflow rate:

Q_T = _____ estimated gpm × 8 = _____ ft³/hr

3. Surface area (SA) of settling basin:

$$SA \text{ (ft}^2\text{)} = \frac{Q_T \text{ (ft}^3\text{/hr)}}{4 \text{ ft}^3\text{/hr/ft}^2} = \frac{\text{_____ ft}^3\text{/hr}}{4 \text{ ft}^3\text{/hr/ft}^2} = \text{_____ ft}^2$$

4. Basin dimensions.

Design basin for length = 3 to 5 times basin width.

Basin width = [SA/R]^{0.5}

SA = basin surface area, ft² (Step 3)

R = length-width ratio

width = [_____ ft² (SA) ÷ _____ (R)]^{0.5} = _____ feet

length = _____ ft (width) × _____ (R) = _____ feet

5. Basin overflow.

Provide a rectangular overflow weir at downstream end of basin. Weir height = 6 inches. Maximum weir length = width of settling basin. Minimum weir length, ft = Q_T/1,250. If a riser pipe is used as an overflow device instead of a rectangular weir, riser pipe diameter, inches = Q_T/274. Do not use a riser pipe smaller than 6 inches in diameter.

Minimum rectangular weir length = Q_T/1,250 = _____ /1,250 = _____ feet

Minimum riser pipe diameter = Q_T/274 = _____ /274 = _____ inches

6. Basin depth.

Use the following as a guide for volume of solids and calculate depth required for desired storage period.

Dirt lots = 2,800 ft³/acre-yr

Concrete lots and confinement buildings = 0.5 × manure production volume (Table 4).

If solids are to be removed from basin by pumping, design the basin to hold an equal volume of water above settled solids.

Solids must be diluted and agitated for pumping. If solids are to be removed mechanically (i.e., front-end loader), provide concrete entrance to settling basin with a maximum 10:1 slope. Additional dewatering by means of a hardware cloth dam or perforated riser pipe is desirable for mechanical removal of settled solids.

Indicate desired storage period, days = _____

$$\text{Basin depth (dirt lot)} = \frac{2,800 \times \text{_____ acre lot} \times \text{_____ days storage} \times 2^*}{365 \text{ days/yr} \times \text{_____ ft}^2 \text{ surface area (Step 3)}} = \text{_____ feet}$$

*Multiply by 1 for mechanical removal or by 2 for pumping.

For a concrete lot or confinement building

$$\text{Basin depth} = \frac{0.5 \times \text{_____ ft}^3\text{/day manure (Table 4)} \times \text{_____ days storage} \times 2^*}{\text{_____ ft}^2 \text{ surface area (Step 3)}}$$

*Multiply by 1 for mechanical removal or by 2 for pumping.

Note: When settling basin discharges into a lagoon, the size of the lagoon may be reduced as follows:

- Design volume (w/settling basin) = Design volume (w/o settling basin) × 0.5
- Manure storage volume (w/settling basin) = Manure storage volume (w/o settling basin) × 0.5

Minimum design storage period is 90 days when the lagoon design volume is reduced by 50 percent, as noted above. Less storage may be used if the lagoon design volume is based on 100 percent loading.



OUTREACH & EXTENSION
UNIVERSITY OF MISSOURI
COLUMBIA

■ Issued in furtherance of Cooperative Extension Work Acts of May 8 and June 30, 1914, in cooperation with the United States Department of Agriculture. Ronald J. Turner, Director, Cooperative Extension, University of Missouri and Lincoln University, Columbia, MO 65211. ■ University Outreach and Extension does not discriminate on the basis of race, color, national origin, sex, religion, age, disability or status as a Vietnam era veteran in employment or programs. ■ If you have special needs as addressed by the Americans with Disabilities Act and need this publication in an alternative format, write ADA Officer, Extension and Agricultural Information, 1-98 Agriculture Building, Columbia, MO 65211, or call (573) 882-7216. Reasonable efforts will be made to accommodate your special needs.